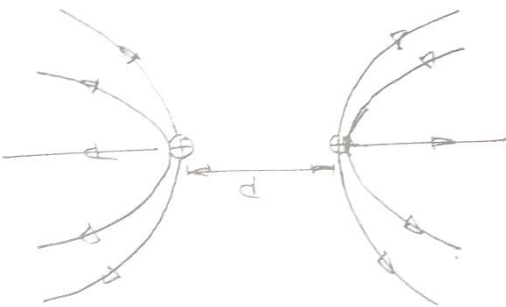

Page 1 of 21
Marking Scheme
55/2/3

Q. No.	Value Points/Expected Answers	Marks	Total Marks
SECTION-A			
Q.1	<div style="border: 1px solid black; padding: 5px; margin-bottom: 10px;"> <ul style="list-style-type: none"> • For writing relationship between susceptibility and temperature 1/2 • Calculating the temperature 1/2 </div> $\chi_m \propto \frac{1}{T}$ $T_2 = \frac{\chi_{m1}}{\chi_{m2}} \times T_1$ $T_2 = \frac{1.2 \times 10^5}{1.44 \times 10^5} \times 300 = 250K$ <p style="text-align: center;">OR</p> <div style="border: 1px solid black; padding: 5px; margin-bottom: 10px;"> <ul style="list-style-type: none"> • For identification of magnetic material 1 </div> <p>It is diamagnetic material</p>	1/2 1/2	1 1
Q.2		1	1
Q.3	<div style="border: 1px solid black; padding: 5px; margin-bottom: 10px;"> <ul style="list-style-type: none"> • To identify the part of the electromagnetic spectrum 1/2 • For writing its frequency range 1/2 </div> <p>Microwaves Frequency range is 10^{10} to 10^{12} Hz</p> <p style="text-align: center;">OR</p>	1/2 1/2	1

Page 2 of 21
Marking Scheme
55/2/3

Q. No.	Value Points/Expected Answers	Marks	Total Marks
	<ul style="list-style-type: none"> • Production of electromagnetic wave 1 <p>Accelerated charge produces an oscillating electric field which produces an oscillating magnetic field, which is a source of oscillating electric field, and so on. Thus electromagnetic waves are produced.</p>	1	1
Q.4	$v = \frac{E}{B}$	1	1
Q.5		1	1
SECTION-B			
Q.6	<div style="border: 1px solid black; padding: 5px; margin-bottom: 10px;"> <ul style="list-style-type: none"> • Ray diagram 1 • Principle $\frac{1}{2}$ • One use $\frac{1}{2}$ </div> <p>Principle is total internal reflection</p> <p>(i) To transmit optic signal</p> <p>(ii) To view the internal organs of human beings (any one)</p>	1	2
Q.7	<div style="border: 1px solid black; padding: 5px; margin-bottom: 10px;"> <ul style="list-style-type: none"> • For writing Einstein's photoelectric equation 1/2 • For writing $E_n = -\frac{13.6}{n^2}$ 1/2 • For finding the value of n 1 </div> <p>From photoelectric equation $h\nu = \phi_0 + eV_s$ $= 2 + 0.55 = 2.55 \text{ eV}$</p>	1/2	

Page 5 of 21
Marking Scheme
55/2/3

Q. No.	Value Points/Expected Answers	Marks	Total Marks
	Resolving power = $\frac{2n \sin \beta}{1.22\lambda}$	1/2	
Q.11	<div style="border: 1px solid black; padding: 5px; margin-bottom: 10px;"> <ul style="list-style-type: none"> • Explaining the cause of bluish color of sky 1 • Appearance of sun red at the time of sun rise and sun set 1 </div> <p>(a) Scattering is inversely proportional to the fourth power of wavelength.</p> <p style="text-align: center;"><i>Or</i></p> <p style="text-align: center;">Shorter wavelength scatters more hence sky appear blue.</p> <p>(b) Red color is least scattered. So by the time light reaches the surface of earth all the colors except red get scattered away.</p>	1 1	2
Q.12	<div style="border: 1px solid black; padding: 5px; margin-bottom: 10px;"> <ul style="list-style-type: none"> • Relation 1/2 • Modified relation in case of line of sight 1 • Range of frequency 1/2 </div> <p>$d = \sqrt{2hR}$</p> <p>In case of line of sight of communication</p> <p>$d = \sqrt{2h_R R} + \sqrt{2h_T R}$</p> <p>Frequency range is above 40Mhz</p>	1/2 1 1/2	2
SECTION-C			
Q.13	<div style="border: 1px solid black; padding: 5px; margin-bottom: 10px;"> <p>(a) Energy level diagram for line 1 Spectra – Lyman series & Helmer series 1</p> <p>(b) Calculating largest and shortest wavelengths of emission. 2</p> </div> <p>(a)</p>		

Page 6 of 21
Marking Scheme
55/2/3

Q. No.	Value Points/Expected Answers	Marks	Total Marks
--------	-------------------------------	-------	-------------

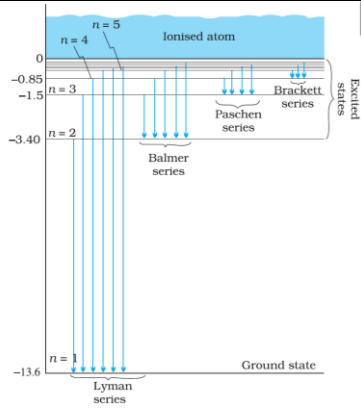

(b)
$$\frac{1}{\lambda_{longest}} = R \left\{ \frac{1}{n_f^2} - \frac{1}{n_c^2} \right\} = R \frac{5}{36}$$

$$\lambda_{max} = \frac{36}{5R}$$

$$= \frac{36}{5 \times 1.1 \times 10^7} m$$

$$= 6.5 \times 10^{-7} m$$

$$\frac{1}{\lambda_{smallest}} = R \left\{ \frac{1}{2^2} - \frac{1}{\infty^2} \right\}$$

$$= \frac{R}{4}$$

$$\lambda_{mm} = \frac{4}{R} = \frac{4}{1.1 \times 10^7} m$$

$$= 3.6 \times 10^{-7} m$$

1

½

3

½

½

½

Q.14

- | | |
|-----------------------------|---|
| • Calculation of impedance | 2 |
| • Calculation of inductance | 1 |

$$Z = \sqrt{R^2 + X_c^2}$$

$$R = \frac{V_R}{I_R} = 30\Omega$$

$$X_c = \frac{V_c}{I_c} = \frac{120}{30} = 40\Omega$$

½

½

½

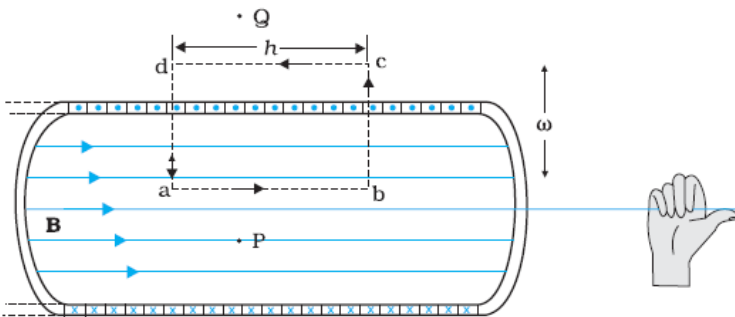
Q. No.	Value Points/Expected Answers	Marks	Total Marks						
	$F_c = F_m$ $\frac{mv^2}{r} = qvB$ $\omega = \frac{qB}{m}$ $v = \frac{qB}{2\pi m}$ <p style="text-align: center;">OR</p> <table border="1" style="width: 100%; border-collapse: collapse;"> <tr> <td>• Diagram of straight solenoid</td> <td style="text-align: right;">1/2</td> </tr> <tr> <td>• Derivation of magnetic field</td> <td style="text-align: right;">1+1/2</td> </tr> <tr> <td>• Difference between toroid and solenoid (any one)</td> <td style="text-align: right;">1</td> </tr> </table> <p>Diagram</p>  <p>Derivation: Let n be the number of turns per unit length. The total number of turns is nh. The enclosed current is $I_e = I(nh)$</p> <p>From Ampere's circuital law</p> $BL = \mu_0 I_e$ $Bh = \mu_0 I(nh)$ $B = \mu_0 nI$ <p>Difference between toroid and solenoid (any one)</p> <p>(a) Solenoid behaves like a bar magnet whereas toroid does not. Or If student writes solenoid is straight and the toroid is circular give half mark. Or there is fringe effect in case of straight solenoid but not in toroid (allot one mark.)</p>	• Diagram of straight solenoid	1/2	• Derivation of magnetic field	1+1/2	• Difference between toroid and solenoid (any one)	1	1/2 1/2 1/2 1/2 1	3 3 3
• Diagram of straight solenoid	1/2								
• Derivation of magnetic field	1+1/2								
• Difference between toroid and solenoid (any one)	1								
Q.17	<table border="1" style="width: 100%; border-collapse: collapse;"> <tr> <td>Circuit diagram</td> <td style="text-align: right;">1</td> </tr> <tr> <td>Working Principle</td> <td style="text-align: right;">1/2</td> </tr> </table>	Circuit diagram	1	Working Principle	1/2				
Circuit diagram	1								
Working Principle	1/2								

Page 12 of 21
Marking Scheme
55/2/3

Q. No.	Value Points/Expected Answers	Marks	Total Marks
	<p>The surface charge density on outer shell is $\sigma_2 = \frac{Q+q}{4\pi r_2^2}$</p> <p>(b) Consider a Gaussian surface inside the shell, net flux is zero since $q_{net} = 0$. According to Gauss's law it is independent of shape and size of shell.</p>	<p>1/2</p> <p>1</p>	<p>3</p>
Q.19	<div style="border: 1px solid black; padding: 5px; margin-bottom: 10px;"> <p>Proving magnetic moment as $\frac{evr}{2}$ 2</p> <p>Deducing expression of the magnetic moment of hydrogen atom 1</p> </div> <p>The magnetic moment is $m = IA$</p> <p>But current is $I = \frac{e}{T} = \frac{ev}{2\pi r}$</p> <p>Where $T = \frac{2\pi r}{v}$ and the area, $A = \pi r^2$</p> $m = \frac{ev}{2\pi r} \pi r^2 = \frac{evr}{2}$ <p>But from Bohr's second postulate</p> $m_e vr = \frac{nh}{2\pi} = \frac{h}{2\pi} \quad \text{for } n=1$ $vr = \frac{nh}{2\pi m_e}$ <p>Hence the magnetic moment is</p> $m = \frac{e}{2} \frac{h}{2\pi m_e} = \frac{eh}{4\pi m_e} \quad (\text{Here } n=1)$	<p>1/2</p> <p>1/2</p> <p>1/2</p> <p>1/2</p> <p>1/2</p> <p>1/2</p>	<p>3</p>
Q.20	<div style="border: 1px solid black; padding: 5px; margin-bottom: 10px;"> <ul style="list-style-type: none"> • Proving the phase difference 1 • Calculation of Amplification factor 1 • Calculation of load resistance 1 </div> <p>Input signal, $V_i = \Delta I_B r_i$</p> <p>Output signal, $V_o = -\Delta I_c R_L$</p> <p>Voltage amplification, $A_v = \frac{V_o}{V_i}$</p> <ul style="list-style-type: none"> • $A_v = -\frac{\Delta I_B}{\Delta I_c} \times \frac{r_i}{R_L}$ • $A_v = -\beta \times \text{resistance gain}$ 	<p>1/2</p> <p>1/2</p>	

Page 13 of 21
Marking Scheme
55/2/3

Q. No.	Value Points/Expected Answers	Marks	Total Marks						
	<p>Here negative sign indicates that output is 180° out of phase w.r.t. input signal.</p> <ul style="list-style-type: none"> • $\beta = \frac{\Delta I_C}{\Delta I_B} = \frac{4 \times 10^{-3}}{30 \times 10^{-6}} = \frac{400}{3}$ $r_i = \frac{\Delta V_{BE}}{\Delta I_B} = \frac{0.02}{30 \times 10^{-6}} = \frac{2 \times 10^{-2}}{3 \times 10^{-5}}$ • $r_i = \frac{2}{3} \times 10^3 \Omega$ $A_v = \beta \frac{R_L}{r_i}$ $R_L = \frac{A_v \times r_i}{\beta} = \frac{400 \times 2 \times 10^3 \times 3}{400 \times 3} = 2 \times 10^3 \Omega$	<p>1</p> <p>½</p> <p>½</p>	<p>3</p>						
Q.21	<table border="1" style="width: 100%; border-collapse: collapse; margin-bottom: 10px;"> <tr> <td style="padding: 5px;">(a) Formula</td> <td style="text-align: center; padding: 5px;">½</td> </tr> <tr> <td style="padding: 5px;"> Combined focal length</td> <td style="text-align: center; padding: 5px;">1</td> </tr> <tr> <td style="padding: 5px;">(b) Expression of angle of incident</td> <td style="text-align: center; padding: 5px;">1 ½</td> </tr> </table> <p>(a) $\frac{1}{F} = \frac{1}{f_1} + \frac{1}{f_2}$</p> $\frac{1}{F} = \frac{1}{36} - \frac{1}{20}$ $\frac{1}{F} = \frac{-100}{600} - \frac{1}{60}$ <p>F = -60 cm</p> <p>The combination works as diverging lens</p> <p>(b) $\mu = \frac{1}{\sin i_c}$</p> $r_1 + r_2 = A$ $r_1 = A - i_c$ $\sin i_1 = \mu \sin r_1$ $\sin i_1 = \mu \sin(A - i_c)$ $i_1 = \sin^{-1} \{ \mu \sin(A - i_c) \}$	(a) Formula	½	Combined focal length	1	(b) Expression of angle of incident	1 ½	<p>½</p> <p>½</p> <p>½</p> <p>½</p> <p>½</p>	<p>3</p>
(a) Formula	½								
Combined focal length	1								
(b) Expression of angle of incident	1 ½								

Q. No.	Value Points/Expected Answers	Marks	Total Marks
--------	-------------------------------	-------	-------------

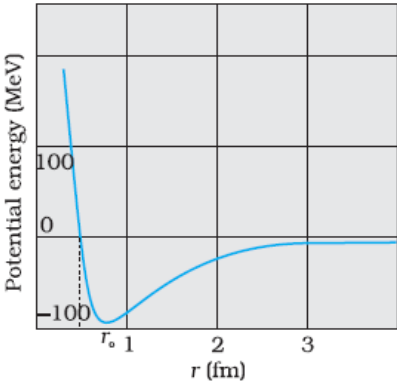
Q.22	<div style="border: 1px solid black; padding: 5px; margin-bottom: 10px;"> <ul style="list-style-type: none"> • Reason for difficulty in detecting presence of anti-neutrino during β-decay 1/2 • Define decay constant of radioactive nucleus 1/2 • Derive expression for mean life in terms of decay constant 2 </div> <ul style="list-style-type: none"> • Penetrating power is high • Do not interact with matter (weak interaction) any one • Decay constant is the reciprocal of the time duration in which undecayed radioactive nuclei reduce to 1/e times the nuclei present initially. <div style="margin-top: 10px;"> $\tau = \frac{\text{total life time of all nuclei}}{\text{total number of nuclei}}$ $\tau = \frac{\int_0^{\infty} t dN}{N_0}$ $\tau = \frac{\int_0^{\infty} t(N_0 \lambda e^{-\lambda t} dt)}{N_0} = \lambda \int_0^{\infty} t e^{-\lambda t} dt$ </div> <div style="margin-top: 10px;"> $\tau = \frac{1}{\lambda}$ </div> <p style="text-align: center; margin: 10px 0;">OR</p> <div style="border: 1px solid black; padding: 5px; margin-bottom: 10px;"> <ul style="list-style-type: none"> (a) Stating distinguishing feature of nuclear force. 1 (b) Drawing a plot showing variation of potential energy. 1 (c) Marking the regions. 1/2+1/2 </div> <ul style="list-style-type: none"> (1) Short rang force (2) Strongest force (3) Attractive in nature (4) Does not depend on charge (any two) <p style="margin-top: 10px;">(b) Figure</p> <div style="display: flex; align-items: center;">  <div style="margin-left: 20px;"> <p>$r < r_0$ repulsive force</p> <p>$r > r_0$ attractive force</p> </div> </div>	<p>1/2</p> <p>1</p> <p>1/2</p> <p>1/2</p> <p>1/2</p> <p>3</p> <p>1</p> <p>1</p> <p>1/2</p> <p>1/2</p>	<p>3</p> <p>3</p>
------	--	---	-------------------

Page 15 of 21
Marking Scheme
55/2/3

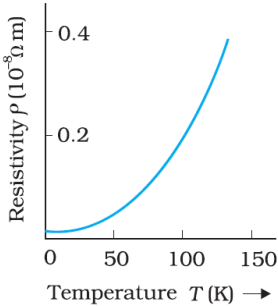
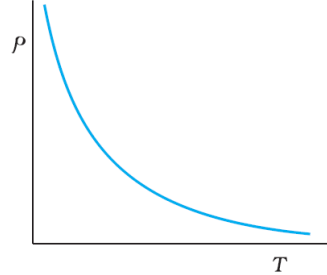
Q. No.	Value Points/Expected Answers	Marks	Total Marks
Q.23	<div style="border: 1px solid black; padding: 5px; margin-bottom: 10px;"> <ul style="list-style-type: none"> • Showing the plot of variation of resistivity 1/2 + 1/2 • Expression for resistivity 1 • Explaining variation of resistivity for conductor and semiconductor 1/2 + 1/2 </div> <div style="display: flex; justify-content: space-around; align-items: center;">   </div> <ul style="list-style-type: none"> • $\rho = \frac{m}{ne^2\tau}$ • In case of conductors with increase in temperature, relaxation time decreases, so resistivity increases. • In case of semiconductors with increase in temperature number density (n) of free electrons increases, hence resistivity increases. 	<p>1/2</p> <p>1/2</p> <p>1</p> <p>1/2</p> <p>1/2</p>	3
Q.24	<div style="border: 1px solid black; padding: 5px; margin-bottom: 10px;"> <ul style="list-style-type: none"> • Derive expression for amplitude modulated wave. 2 • Deducing expression for lower and upper side bands. 1/2 • Obtaining expression for modulation index. 1/2 </div> <p>Let a carrier wave be given by $c(t) = A_c \sin \omega_c t$ where $\omega_c = 2\pi f_c$ And signal wave be $m(t) = A_m \sin \omega_m t$ where $\omega_m = 2\pi f_m$ The modulated signal is $c_m(t) = (A_c + A_m \sin \omega_m t) \sin \omega_c t$ $c_m(t) = A_c \left(1 + \frac{A_m}{A_c} \sin \omega_m t\right) \sin \omega_c t$ $c_m(t) = A_c \sin \omega_c t + \mu \frac{A_c}{2} \cos(\omega_c - \omega_m)t - \mu \frac{A_c}{2} \cos(\omega_c + \omega_m)t$</p> <p>The modulation index $\mu = \frac{A_m}{A_c}$</p>	<p>1/2</p> <p>1/2</p> <p>1/2</p> <p>1/2</p>	

Q. No.	Value Points/Expected Answers	Marks	Total Marks
	Lower frequency band $\omega_c - \omega_m$ Upper frequency band $\omega_c + \omega_m$	1/2 1/2	3

SECTION-D

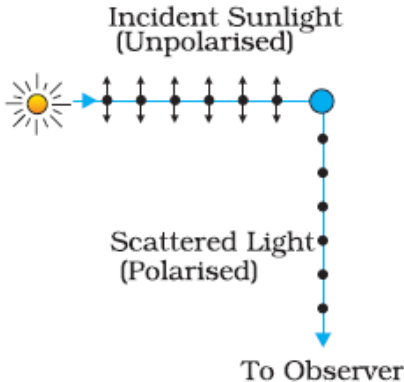
Q.25	<div style="border: 1px solid black; padding: 5px; margin-bottom: 10px;"> <ul style="list-style-type: none"> Diagram production of polarized light by scattering of sun light 1 Explanation 1 Calculation of intensity of light transmitted through P_1, P_2 and P_3 1/2 + 1 + 1 1/2 </div> <p>Diagram:</p> <div style="text-align: center; margin: 10px 0;">  </div> <p>Explanation: Charges accelerating parallel to the double arrows do not radiate energy towards the observer. The radiation scattered by the molecules therefore is polarised perpendicular to the plane of the figure. ALTERNATIVELY : If the student writes " scattered light when viewed in a perpendicular direction is found to be polarised " (award one mark)</p> <p>Intensity of light transmitted by 1st Polaroid is, $I_1 = \frac{I}{2}$</p> <p>Intensity of light transmitted by 2nd Polaroid is, $I_2 = I_1 \cos^2 45^\circ = \frac{I}{2} \left(\frac{1}{\sqrt{2}} \right)^2 = \frac{I}{4}$</p> <p>Intensity of light transmitted by 3rd Polaroid is, $I_3 = I_2 \cos^2 45^\circ = \frac{I}{2} \left(\frac{1}{\sqrt{2}} \right)^2 = \frac{I}{8}$</p> <p style="text-align: center;">OR</p> <div style="border: 1px solid black; padding: 5px; margin-top: 10px;"> <ul style="list-style-type: none"> Reason 1/2 Deriving the expression for resultant intensity and condition for constructive and destructive interference 1 1/2 + 1/2 + 1/2 Calculating the separation 2 </div>	1	1	1/2	1	5
------	--	---	---	-----	---	---

Q. No.	Value Points/Expected Answers	Marks	Total Marks
	<p>(a) Because two independent sources cannot be coherent OR they are not coherent</p> <p>(b) $y_1 = a \cos \omega t$ $y_2 = a \cos(\omega t + \phi)$ So resultant displacement is give by $y = y_1 + y_2$ $y = a \cos \omega t + a \cos(\omega t + \phi)$ $y = 2a \cos(\phi / 2) \cos(\omega t + \phi / 2)$ The amplitude of the resultant displacement is $2a \cos(\phi / 2)$ and therefore intensity at that point will be $I = 4I_0 \cos^2(\phi / 2)$ For constructive interference: $\phi = 0, \pm 2\pi, \pm 4\pi, \dots$ For destructive interference: $\phi = \pm \pi, \pm 3\pi, \pm 5\pi, \dots$</p> <p>(c) Position of second maxima $y_2 = \frac{5 \lambda D}{2 a}$ Separation between the positions of the second maxima with λ_1 and λ_2 is: $\Delta y = \frac{5D(\lambda_2 - \lambda_1)}{2a} = \frac{5 \times 1.5 \times (596 - 590) \times 10^{-9}}{2 \times 2 \times 10^{-6}} = 11.25 \times 10^{-3} m$</p>	<p>$\frac{1}{2}$</p> <p>1</p> <p>$\frac{1}{2}$</p> <p>$\frac{1}{2}$</p> <p>1</p> <p>1</p>	5
Q.26	<div style="border: 1px solid black; padding: 10px; margin-bottom: 10px;"> <ul style="list-style-type: none"> • Circuit diagram and describing the method to measure internal resistance of cell by potentiometer 1+1 • Reason 1 • Calculating balancing length and reason (circuit works or not) 1½ +1 </div> <p>(a) Circuit diagram:</p>	1	

Page 18 of 21
Marking Scheme
55/2/3

Q. No.	Value Points/Expected Answers	Marks	Total Marks						
	<p>Brief description: Plug in the key k_1 and keep k_2 unplugged and the find the balancing length l_1 such that: $E = kl_1$ (1)</p> <p>With the key k_2 also plugged in find out balancing length l_2 again such that: $V = kl_2$ (2) As $r = \left(\frac{E}{V} - 1\right)R$ $r = \left(\frac{l_1}{l_2} - 1\right)R$</p> <p>(b) The potentiometer is preferred over the voltmeter for measurement of e.m.f. of a cell because potentiometer draws no current from the voltage source being measured.</p> <p>(c) $V = 5V$, $R_{AB} = 50\Omega$, $R = 450\Omega$ $I = \frac{5}{450+50} = \frac{1}{100} = 0.01A$ $V_{AB} = 0.01 \times 50 = 0.5V$ $k = \frac{0.5}{10} = 0.05Vm^{-1}$ $l = \frac{V}{k} = \frac{300 \times 10^{-3}}{0.05} = 6m$</p> <p>With 2V driver cell current in the circuit is $I = \frac{2}{450+50} = 0.004A$. P.d. across AB is $= 0.004 \times 50 = 200mV$. Hence the circuit will not work.</p> <p style="text-align: center;">OR</p> <table border="1" style="margin-left: auto; margin-right: auto;"> <tr> <td>• State the working principle of meter bridge</td> <td style="text-align: right;">1</td> </tr> <tr> <td>• Reasons</td> <td style="text-align: right;">1/2 + 1/2</td> </tr> <tr> <td>• Calculation of potential difference using Kirchhoff's rules</td> <td style="text-align: right;">3</td> </tr> </table> <p>(a) Meter bridge is based on the principle of balanced Wheatstone bridge.</p> <p>(b) (i) Thick copper strips are used to minimize resistance of connections which are not accounted for in the bridge formula (ii) Balance point is preferred near midpoint of bridge wire to minimize percentage error in resistance (R).</p> <p>(c)</p>	• State the working principle of meter bridge	1	• Reasons	1/2 + 1/2	• Calculation of potential difference using Kirchhoff's rules	3	<p>1/2</p> <p>1/2</p> <p>1/2</p> <p>s</p> <p>1/2</p> <p>1/2</p> <p>1/2</p> <p>1/2</p> <p>1/2</p> <p>1/2</p> <p>1/2</p> <p>1</p> <p>1/2</p> <p>1/2</p>	
• State the working principle of meter bridge	1								
• Reasons	1/2 + 1/2								
• Calculation of potential difference using Kirchhoff's rules	3								

Q. No.	Value Points/Expected Answers	Marks	Total Marks
--------	-------------------------------	-------	-------------

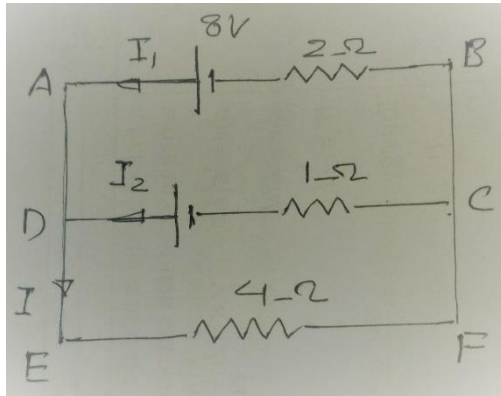

$$I = I_1 + I_2 \quad (1)$$

In loop ABCDA

$$-8 + 2I_1 - 1 \times I_2 + 6 = 0 \quad (2)$$

In loop DEFCD

$$-4I - 1 \times I_2 + 6 = 0$$

$$4I + I_2 = 6$$

$$4(I_1 + I_2) + I_2 = 6$$

$$4I_1 + 5I_2 = 6 \quad (3)$$

From equations (1) and (2) we get

$$I_1 = \frac{8}{7} \text{ A}, \quad I_2 = \frac{2}{7} \text{ A}, \quad I = \frac{10}{7}$$

Potential difference across resistor 4Ω is:

$$V = \frac{10}{7} \times 4 = \frac{40}{7} \text{ volt}$$

1

1

$\frac{1}{2}$

$\frac{1}{2}$

5

Q.27

- | | |
|--|---|
| • Deriving expression for e.m.f. | 3 |
| • Finding induced e.m.f. between the axel and rim of wheel | 2 |

Flux linked with the coil at any instant of time is:

$$\phi = NBA \cos \omega t$$

$$\frac{d\phi}{dt} = NBA\omega(-\sin \omega t) \text{ S}$$

$$\varepsilon = -\frac{d\phi}{dt}$$

$$\varepsilon = NBA\omega \sin \omega t$$

$$\varepsilon = \varepsilon_0 \sin \omega t \quad (\text{Here } \varepsilon_0 = NBA\omega)$$

$\frac{1}{2}$

1

$\frac{1}{2}$

Page 21 of 21
Marking Scheme
55/2/3

Q. No.	Value Points/Expected Answers	Marks	Total Marks
	<p>Force is attractive</p> $f_2 = \frac{2\mu_0 I_1 I_2}{4\pi r_2}$ $f_2 = \frac{2 \times 10^{-7} \times 1 \times 0.2}{15 \times 10^{-2}} = 2.6 \times 10^{-7} \text{ Nm}^{-1}$ <p>Force is repulsive</p> <p>So the net force experienced by the loop is (per unit length)</p> $f = (f_1 - f_2)$ <p>Total force experienced by the loop is:</p> $F = (f_1 - f_2)l = (1.4 \times 10^{-7}) \times 5 \times 10^{-2}$ $F = 7 \times 10^{-7} \text{ N}$ <p>Net force is attractive in nature</p> <p>As forces act along the same line, torque is zero.</p>	<p>1/2</p> <p>1/2</p> <p>1/2</p> <p>1/2</p>	<p>5</p>