

Marking Scheme
Strictly Confidential
(For Internal and Restricted use only)
Senior School Certificate Examination, 2024
SUBJECT- PHYSICS (CODE 55/2/3)

General Instructions: -

1	You are aware that evaluation is the most important process in the actual and correct assessment of the candidates. A small mistake in evaluation may lead to serious problems which may affect the future of the candidates, education system and teaching profession. To avoid mistakes, it is requested that before starting evaluation, you must read and understand the spot evaluation guidelines carefully.
2	“Evaluation policy is a confidential policy as it is related to the confidentiality of the examinations conducted, Evaluation done and several other aspects. Its’ leakage to public in any manner could lead to derailment of the examination system and affect the life and future of millions of candidates. Sharing this policy/document to anyone, publishing in any magazine and printing in News Paper/Website etc. may invite action under various rules of the Board and IPC.”
3	Evaluation is to be done as per instructions provided in the Marking Scheme. It should not be done according to one’s own interpretation or any other consideration. Marking Scheme should be strictly adhered to and religiously followed. However, while evaluating, answers which are based on latest information or knowledge and/or are innovative, they may be assessed for their correctness otherwise and due marks be awarded to them. In class-X, while evaluating two competency-based questions, please try to understand given answer and even if reply is not from marking scheme but correct competency is enumerated by the candidate, due marks should be awarded.
4	The Marking scheme carries only suggested value points for the answers These are in the nature of Guidelines only and do not constitute the complete answer. The students can have their own expression and if the expression is correct, the due marks should be awarded accordingly.
5	The Head-Examiner must go through the first five answer books evaluated by each evaluator on the first day, to ensure that evaluation has been carried out as per the instructions given in the Marking Scheme. If there is any variation, the same should be zero after deliberation and discussion. The remaining answer books meant for evaluation shall be given only after ensuring that there is no significant variation in the marking of individual evaluators.
6	Evaluators will mark (√) wherever answer is correct. For wrong answer CROSS ‘X’ be marked. Evaluators will not put right (✓) while evaluating which gives an impression that answer is correct and no marks are awarded. This is most common mistake which evaluators are committing.
7	If a question has parts, please award marks on the right-hand side for each part. Marks awarded for different parts of the question should then be totaled up and written in the left-hand margin and encircled. This may be followed strictly.
8	If a question does not have any parts, marks must be awarded in the left-hand margin and encircled. This may also be followed strictly.
9	If a student has attempted an extra question, answer of the question deserving more marks should be

	retained and the other answer scored out with a note “ Extra Question ”.
10	No marks to be deducted for the cumulative effect of an error. It should be penalized only once.
11	A full scale of marks 0 – 70 has to be used. Please do not hesitate to award full marks if the answer deserves it.
12	Every examiner has to necessarily do evaluation work for full working hours i.e., 8 hours every day and evaluate 20 answer books per day in main subjects and 25 answer books per day in other subjects (Details are given in Spot Guidelines). This is in view of the reduced syllabus and number of questions in question paper.
13	<p>Ensure that you do not make the following common types of errors committed by the Examiner in the past:-</p> <ul style="list-style-type: none"> ● Leaving answer or part thereof unassessed in an answer book. ● Giving more marks for an answer than assigned to it. ● Wrong totaling of marks awarded on an answer. ● Wrong transfer of marks from the inside pages of the answer book to the title page. ● Wrong question wise totaling on the title page. ● Wrong totaling of marks of the two columns on the title page. ● Wrong grand total. ● Marks in words and figures not tallying/not same. ● Wrong transfer of marks from the answer book to online award list. ● Answers marked as correct, but marks not awarded. (Ensure that the right tick mark is correctly and clearly indicated. It should merely be a line. Same is with the X for incorrect answer.) ● Half or a part of answer marked correct and the rest as wrong, but no marks awarded.
14	While evaluating the answer books if the answer is found to be totally incorrect, it should be marked as cross (X) and awarded zero (0) Marks.
15	Any unassessed portion, non-carrying over of marks to the title page, or totaling error detected by the candidate shall damage the prestige of all the personnel engaged in the evaluation work as also of the Board. Hence, in order to uphold the prestige of all concerned, it is again reiterated that the instructions be followed meticulously and judiciously.
16	The Examiners should acquaint themselves with the guidelines given in the “ Guidelines for Spot Evaluation ” before starting the actual evaluation.
17	Every Examiner shall also ensure that all the answers are evaluated, marks carried over to the title page, correctly totaled and written in figures and words.
18	The candidates are entitled to obtain photocopy of the Answer Book on request on payment of the prescribed processing fee. All Examiners/Additional Head Examiners/Head Examiners are once again reminded that they must ensure that evaluation is carried out strictly as per value points for each answer as given in the Marking Scheme.

MARKING SCHEME : PHYSICS (042)			
CODE :55/2/3			
Q.No	VALUE POINTS/EXPECTED ANSWERS	MARKS	TOTAL MARKS
SECTION-A			
1.	(D) $\frac{1}{3}$	1	1
2.	(A) $\frac{v_d}{2}$	1	1
3.	(B) Resistance of the coil	1	1
4.	(C) $31.4\mu\text{Wb}$	1	1
5.	(D) Magnetic Flux and Power both	1	1
6.	(A) $\frac{5\pi}{6}$	1	1
7.	(C) III	1	1
8.	(B) 8×10^{-28}	1	1
9.	(C) P	1	1
10.	(B) $\frac{1}{\lambda_1} + \frac{1}{\lambda_2} = \frac{1}{\lambda_3}$	1	1
11.	(B) The barrier height increases and the depletion region widens.	1	1
12.	(C) $\frac{1}{K}$	1	1
13.	(A) Both Assertion(A) and Reason (R) are true and Reason(R) is the correct explanation of the Assertion (A)	1	1
14.	(C) Assertion(A) is true, but Reason (R) is false	1	1
15.	(B) Both Assertion(A) and Reason (R) are true but Reason(R) is not the correct explanation of the Assertion (A)	1	1
16.	(A) Both Assertion(A) and Reason (R) are true and Reason(R) is the correct explanation of the Assertion (A)	1	1
SECTION- B			
17.	<div style="border: 1px solid black; padding: 5px; display: inline-block; margin-bottom: 10px;"> Deriving relation 2 </div> $V = IR$ $El = \frac{I\rho l}{A} \quad (V = El, R = \frac{\rho l}{A})$ $E = \frac{I}{A}\rho$ $E = \sigma\rho$	 $\frac{1}{2}$ $\frac{1}{2}$ $\frac{1}{2}$ $\frac{1}{2}$	2
18.	<div style="border: 1px solid black; padding: 5px; display: inline-block; margin-bottom: 10px;"> Effect on energy gap and justification (i) Trivalent impurity $\frac{1}{2} + \frac{1}{2}$ (ii) Pentavalent impurity $\frac{1}{2} + \frac{1}{2}$ </div> (i) Decreases Justification: An acceptor energy level is formed just above the top of the valence band.	 $\frac{1}{2}$ $\frac{1}{2}$	

	<p>Alternatively Interference pattern is not formed. (Note : Award full credit of this part if a student merely attempts this part.)</p> <p>(ii) $\beta = \frac{\lambda D}{d}$</p> <p>As d increases, β decreases and fringes disappear.</p>	$\frac{1}{2}$							
		$\frac{1}{2}$	2						
20.	<table border="1" style="width: 100%;"> <tr> <td style="width: 80%;">Finding ratio of period of revolution</td> <td style="width: 20%; text-align: right;">2</td> </tr> </table> <p>$T = \frac{2\pi r_n}{v_n}$</p> <p>$r_n \propto n^2$</p> <p>$v_n \propto \frac{1}{n}$</p> <p>$T \propto n^3$</p> <p>$\frac{T_2}{T_1} = \frac{(n_2)^3}{(n_1)^3}$</p> <p>$= \frac{(2)^3}{(1)^3}$</p> <p>$= \frac{8}{1}$</p>	Finding ratio of period of revolution	2	$\frac{1}{2}$					
Finding ratio of period of revolution	2								
		$\frac{1}{2}$							
		$\frac{1}{2}$							
		$\frac{1}{2}$							
		$\frac{1}{2}$	2						
21.	<table border="1" style="width: 100%;"> <tr> <td style="width: 80%;">Finding focal length</td> <td style="width: 20%; text-align: right;">1 $\frac{1}{2}$</td> </tr> <tr> <td>Nature of the lens</td> <td style="text-align: right;">$\frac{1}{2}$</td> </tr> </table> <p>For convex lens in air</p> <p>$\frac{1}{f_a} = \left(\frac{n_g}{n_a} - 1\right) \left(\frac{1}{R_1} - \frac{1}{R_2}\right)$</p> <p>For convex lens in liquid.</p> <p>$\frac{1}{f_l} = \left(\frac{n_g}{n_l} - 1\right) \left(\frac{1}{R_1} - \frac{1}{R_2}\right)$</p> <p>$\frac{f_l}{f_a} = \frac{1.52 - 1}{1.52 - 1.65}$</p> <p>$= -6.6$</p> <p>$f_l = -6.6 f_a$</p> <p>$= -99\text{cm}$</p> <p>Nature of the lens: Diverging/ behaves like a concave lens.</p>	Finding focal length	1 $\frac{1}{2}$	Nature of the lens	$\frac{1}{2}$	$\frac{1}{2}$			
Finding focal length	1 $\frac{1}{2}$								
Nature of the lens	$\frac{1}{2}$								
		$\frac{1}{2}$							
		$\frac{1}{2}$							
		$\frac{1}{2}$	2						
SECTION- C									
22.	<p>(a)</p> <table border="1" style="width: 100%;"> <tr> <td style="width: 80%;">Explaining nature of force</td> <td style="width: 20%; text-align: right;">$\frac{1}{2}$</td> </tr> <tr> <td>Obtaining expression of force</td> <td style="text-align: right;">1 $\frac{1}{2}$</td> </tr> <tr> <td>Defining one ampere</td> <td style="text-align: right;">1</td> </tr> </table>	Explaining nature of force	$\frac{1}{2}$	Obtaining expression of force	1 $\frac{1}{2}$	Defining one ampere	1		
Explaining nature of force	$\frac{1}{2}$								
Obtaining expression of force	1 $\frac{1}{2}$								
Defining one ampere	1								

Nature of force is repulsive.

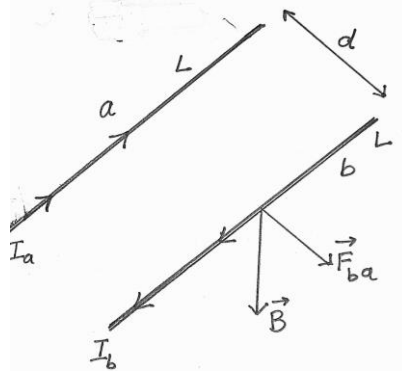

1/2

Magnetic field due to current I_a at all points of conductor b

$$B_{ab} = \frac{\mu_0 I_a}{2\pi d} \quad \text{directed downwards}$$

1/2

Force experienced by conductor b on its segment of length l

$$F_{ab} = I_b B_{ab} \\ = \frac{\mu_0 I_a I_b}{2\pi d} l \quad \text{directed towards left}$$

1/2

Similarly

Force experienced by conductor a on its segment of length l

$$F_{ba} = \frac{\mu_0 I_a I_b}{2\pi d} l \quad \text{directed towards right}$$

One ampere is that steady current which when maintained in each of two very long straight parallel conductors of negligible cross-section, placed one metre apart in vacuum produces a force of $2 \times 10^{-7} \text{ N/m}$ on each conductor.

1

OR

(b)	Obtaining expression of torque	2
	Drawing diagram	1

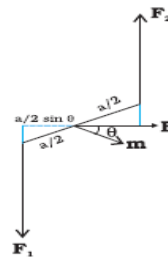
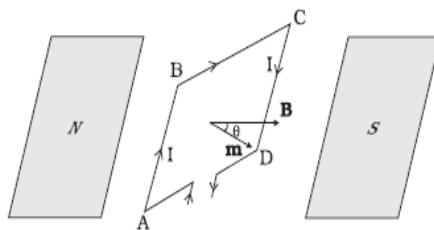

1

1/2

Forces on arm BC and DA are equal and opposite and act along the axis of the coil. Being collinear they cancel each other.

Forces on arms AB and CD are equal and opposite but not collinear. They form a couple.

$$F_1 = F_2 = IbB$$

1/2

$$\tau = F_1 \frac{a}{2} \sin \theta + F_2 \frac{a}{2} \sin \theta$$

1/2

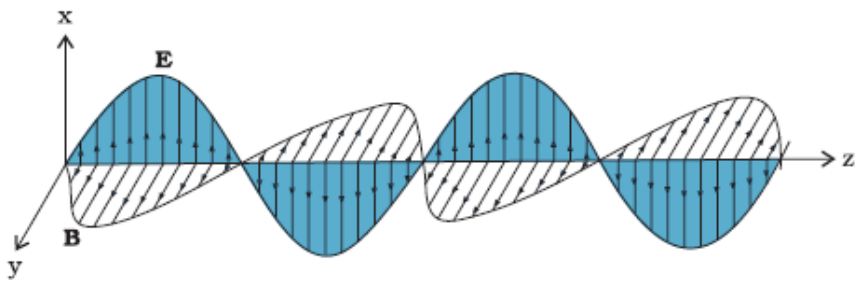
	$\tau = IabB \sin \theta$ $\tau = IAB \sin \theta$ (where $A = ab$ & $m = IA$) $\vec{\tau} = \vec{m} \times \vec{B}$	$\frac{1}{2}$	3
23.	<div style="border: 1px solid black; padding: 5px; margin-bottom: 10px;"> (a) Factors affecting speed of Electromagnetic wave 1 (b) Production of Electromagnetic wave 1 (c) Sketch of Electromagnetic wave 1 </div> <p>(a) Speed of EM waves $v = \frac{1}{\sqrt{\mu\epsilon}}$</p> <p>Speed depends upon</p> <p>(i) Permittivity (ϵ) of medium</p> <p>(ii) Magnetic permeability (μ) of medium</p> <p>(b) Accelerated charges or oscillating charges produce electromagnetic waves</p> <p>(c)</p> 	$\frac{1}{2} + \frac{1}{2}$	1
24.	<div style="border: 1px solid black; padding: 5px; margin-bottom: 10px;"> (a) Finding output voltage 1 (b) Finding instantaneous voltage 1 (c) Finding current 1 </div> <p>(a) $V_p(\text{rms}) = \frac{140}{\sqrt{2}} = \frac{140}{1.4} = 100V$</p> <p>$\therefore V_s = \frac{N_s}{N_p} V_p = \frac{1000}{200} 100 = 500V$</p> <p>(b) $v_s = 500\sqrt{2} \sin 100pt = 700 \sin 100pt$</p> <p>(c) Power Output = Power Input</p> <p>$I_s = \frac{5000}{500} = 10A$</p>	$\frac{1}{2}$	$\frac{1}{2}$
25.	<div style="border: 1px solid black; padding: 5px; margin-bottom: 10px;"> Finding magnitude and direction of current in AG, BF and CD 1+1+1 </div>	1	3

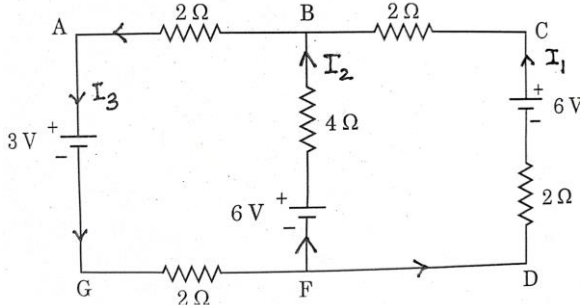
	 <p>By Kirchoff's Laws (at point B)</p> $I_1 + I_2 = I_3 \quad \dots\dots(1)$ <p>In the closed loop AGFBA</p> $3 + 2I_3 - 6 + 4I_2 + 2I_3 = 0$ $I_2 + I_3 = \frac{3}{4} \quad \dots\dots(2)$ <p>From (i)</p> $2I_1 + I_2 = \frac{3}{4} \quad \dots\dots(3)$ <p>In closed loop BFDCB</p> $-4I_2 + 6 + 2I_1 - 6 + 2I_1 = 0$ $I_2 - I_1 = 0$ $I_2 = I_1 \quad \dots\dots(4)$ <p>Putting in (3)</p> $I_1 = \frac{1}{4} A$ <p>From (4)</p> $I_2 = \frac{1}{4} A$ <p>From (2) $I_3 = \frac{1}{2} A$</p>	<p>1/2</p> <p>1/2</p> <p>1/2</p> <p>1/2</p> <p>1/2</p> <p>1/2</p> <p>1/2</p>	<p>3</p>						
<p>26.</p>	<table border="1" data-bbox="321 1192 1230 1283"> <tbody> <tr> <td>(a) Three characteristics</td> <td>1 1/2</td> </tr> <tr> <td>(b) Identifying more stable nucleus and reason</td> <td>1 1/2</td> </tr> </tbody> </table> <p>(a) Characteristics of nuclear forces :-</p> <ol style="list-style-type: none"> 1. Saturated in nature 2. Attractive for distances larger than r_0 and repulsive for distance less than r_0 3. Do not depend on nature of electric charge i.e. same for n-n, n-p and p-p pairs. 4. Much stronger than gravitational forces. <p>(Any three)</p> <p>(b) 8_4X is more stable</p> <p>The ratio of number of neutrons to the number of protons is more in 8_4X than 5_3Y</p>	(a) Three characteristics	1 1/2	(b) Identifying more stable nucleus and reason	1 1/2	<p>1 1/2</p> <p>1/2</p>	<p>3</p>		
(a) Three characteristics	1 1/2								
(b) Identifying more stable nucleus and reason	1 1/2								
<p>27.</p>	<table border="1" data-bbox="347 1724 1240 1864"> <tbody> <tr> <td>(a) Drawing schematic arrangement</td> <td>1</td> </tr> <tr> <td>(b) Explaining conclusions</td> <td>1</td> </tr> <tr> <td>(c) Defining distance of closest approach</td> <td>1</td> </tr> </tbody> </table>	(a) Drawing schematic arrangement	1	(b) Explaining conclusions	1	(c) Defining distance of closest approach	1		
(a) Drawing schematic arrangement	1								
(b) Explaining conclusions	1								
(c) Defining distance of closest approach	1								

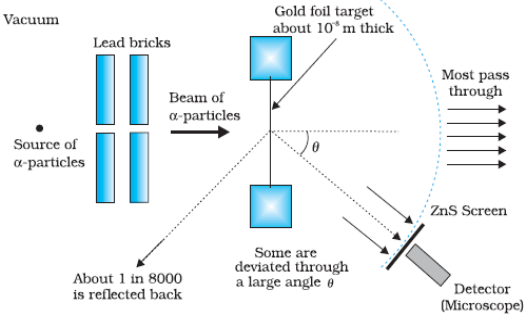
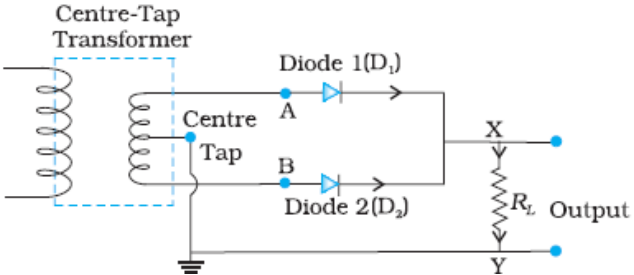
	 <p>(b) -Entire positive charge and most of the mass of atom are concentrated in the nucleus.</p> <ul style="list-style-type: none"> - Electrons move in orbits about the nucleus just as planets around the sun. - Size of nucleus is about 10^{-15} m to 10^{-14} m. - Most of the space in an atom is empty. <p>(c) The distance of the α particle from the centre of nucleus at which the whole of the initial kinetic energy of the particle gets converted into the electric potential energy.</p> <p>Alternatively The distance of the α particle from the centre of nucleus at which it stops momentarily and reverses its direction.</p>	<p>1</p> <p>1</p> <p>1</p>	<p>3</p>				
<p>28.</p>	<table border="1" data-bbox="284 961 1252 1066"> <tr> <td>Explaining working of full wave rectifier</td> <td>2</td> </tr> <tr> <td>Drawing input and output wave forms</td> <td>1</td> </tr> </table>  <p>When input voltage at A with respect to the centre tap at any instant is positive, at that instant voltage at B, being out of phase will be negative, during the positive half cycle diode D_1 gets forward biased and conducts while diode D_2 gets reverse biased and does not conduct. Hence during positive half cycle an output current and output voltage across R_L is obtained.</p> <p>During second half of the cycle when voltage at A becomes negative with respect to centre tap, the voltage at B would be positive hence D_1 would not conduct but D_2 would be giving an output current and output voltage. We get output voltage in both positive and negative half cycles.</p>	Explaining working of full wave rectifier	2	Drawing input and output wave forms	1	<p>1</p> <p>$\frac{1}{2}$</p> <p>$\frac{1}{2}$</p>	
Explaining working of full wave rectifier	2						
Drawing input and output wave forms	1						

		1	3																		
29.	<p>(i) Since no option is correct, award 1 mark to all students.</p> <p>(ii) (D) 800 nm</p> <p>(iii) (a) (A) $\frac{\sqrt{3}}{2}$</p> <p style="text-align: center;">OR</p> <p>(b) (B) $\sin^{-1}\left(\frac{4}{5}\right)$</p> <p>(iv) (A) $\sin^{-1}\sqrt{n^2 - 1}$</p>	1 1 1 1	4																		
30.	<p>(i) (B) The internal resistance of a cell decreases with the decrease in temperature of the electrolyte.</p> <p>(ii) (B) 2.8 V</p> <p>(iii) (A) $\varepsilon = V_+ + V_- > 0$</p> <p>(iv) (a) (D) 0.2A</p> <p style="text-align: center;">OR</p> <p>(b) (A) 1.0Ω</p>	1 1 1 1	4																		
31.	<p>(a)</p> <table border="1" style="width: 100%;"> <tr> <td>(i) Two differences between interference pattern and diffraction pattern</td> <td style="text-align: right;">2</td> </tr> <tr> <td>(ii) Intensity distribution graph</td> <td style="text-align: right;">1</td> </tr> <tr> <td>(iii) Finding intensity of light</td> <td style="text-align: right;">2</td> </tr> </table> <p>(i)</p> <table border="1" style="width: 100%; text-align: center;"> <thead> <tr> <th></th> <th>Interference</th> <th>Diffraction</th> </tr> </thead> <tbody> <tr> <td>1</td> <td>Bands are equally spaced</td> <td>Bands are not equally spaced.</td> </tr> <tr> <td>2</td> <td>Intensity of bright bands is same.</td> <td>Intensity of maxima decreases on either side of central maxima.</td> </tr> <tr> <td>3</td> <td>First maxima is at an angle λ/a</td> <td>First minima is at an angle λ/a</td> </tr> </tbody> </table> <p>(ii)</p> <p style="text-align: center;">→ Path difference</p> <p>(iii) Path difference (Δ) = λ</p>	(i) Two differences between interference pattern and diffraction pattern	2	(ii) Intensity distribution graph	1	(iii) Finding intensity of light	2		Interference	Diffraction	1	Bands are equally spaced	Bands are not equally spaced.	2	Intensity of bright bands is same.	Intensity of maxima decreases on either side of central maxima.	3	First maxima is at an angle λ/a	First minima is at an angle λ/a	1 + 1 1	
(i) Two differences between interference pattern and diffraction pattern	2																				
(ii) Intensity distribution graph	1																				
(iii) Finding intensity of light	2																				
	Interference	Diffraction																			
1	Bands are equally spaced	Bands are not equally spaced.																			
2	Intensity of bright bands is same.	Intensity of maxima decreases on either side of central maxima.																			
3	First maxima is at an angle λ/a	First minima is at an angle λ/a																			

$$\phi = \frac{2\pi\Delta}{\lambda}$$

$$\phi = 2\pi$$

$$I = 4I_0 \cos^2 \frac{\phi}{2}$$

$$K = 4I_0 \cos^2 \pi = 4I_0$$

$$\text{Path difference} = \frac{\lambda}{6}$$

$$\phi = \pi / 3$$

$$I = 4I_0 \cos^2 \frac{\pi}{6}$$

$$= 4I_0 \times \frac{3}{4}$$

$$= \frac{3}{4} K$$

1/2

1/2

1/2

1/2

OR

(b)

(i) Drawing labeled ray diagram	1
Derivation of magnifying power	2
(iii) Finding magnifying power	2

(i)

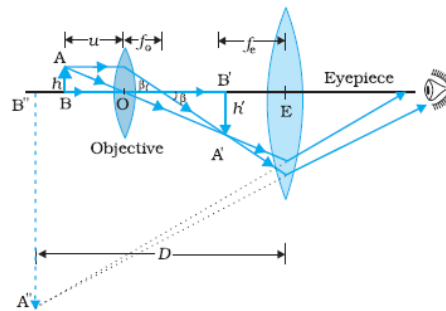

1

The magnification obtained by eye-piece lens $m_e = \left(1 + \frac{D}{f_e}\right)$

1/2

The magnification obtained by objective lens $m_o = \frac{v_o}{-u_o}$

1/2

Hence the total magnifying power is

$$m = m_o \times m_e$$

$$= \frac{v_o}{-u_o} \left(1 + \frac{D}{f_e}\right)$$

1/2

1/2

$$(ii) m = \left| \frac{f_o}{f_e} \right|$$

1

Identification of focal length of objective and eyepiece

$$f_o = 100\text{cm}$$

$$f_e = 5\text{cm}$$

1/2

$$m = \left| \frac{100}{5} \right| = 20$$

1/2

5

32.

(a)	(i) Obtaining expression for electric potential	3
	(ii) Finding the value of n	2

(i)

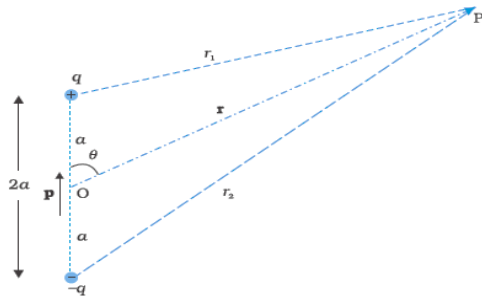

1/2

Potential due to the dipole is the sum of potentials due to charges q and -q

$$V = \frac{1}{4\pi\epsilon_0} \left(\frac{q}{r_1} - \frac{q}{r_2} \right) \text{-----(1)}$$

1/2

By geometry

$$r_1^2 = r^2 + a^2 - 2ar \cos \theta$$

$$r_2^2 = r^2 + a^2 + 2ar \cos \theta$$

1/2

For $r \gg a$, retaining terms only up to first order in a/r

$$r_1^2 = r^2 \left(1 - \frac{2a \cos \theta}{r} + \frac{a^2}{r^2} \right)$$

$$\cong r^2 \left(1 - \frac{2a \cos \theta}{r} \right)$$

Similarly

$$r_2^2 \cong r^2 \left(1 + \frac{2a \cos \theta}{r} \right)$$

1/2

Using the binomial theorem and retaining terms up to the first order in a/r

$$\frac{1}{r_1} \cong \frac{1}{r} \left(1 - \frac{2a \cos \theta}{r} \right)^{-1/2}$$

$$\cong \frac{1}{r} \left(1 + \frac{a \cos \theta}{r} \right) \text{-----(2)}$$

$$\frac{1}{r_2} \cong \frac{1}{r} \left(1 + \frac{2a \cos \theta}{r} \right)^{-1/2} \text{-----(3)}$$

$$\cong \frac{1}{r} \left(1 - \frac{a \cos \theta}{r} \right)$$

1/2

Using eqn. (1) (2), (3) and $p = 2qa$

$$V = \frac{q}{4\pi\epsilon_0} \frac{2a \cos \theta}{r^2}$$

$$= \frac{p \cos \theta}{4\pi\epsilon_0 r^2}$$

1/2

Alternatively –

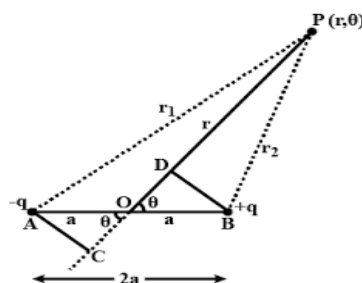

1/2

$r_2 = r + a \cos \theta$ $r_1 = r - a \cos \theta$ $V = \frac{q}{4\pi\epsilon_0} \left(\frac{1}{r_1} - \frac{1}{r_2} \right)$ $V = \frac{q}{4\pi\epsilon_0} \left(\frac{1}{r - a \cos \theta} - \frac{1}{r + a \cos \theta} \right)$ $= \frac{q}{4\pi\epsilon_0} \left(\frac{2a \cos \theta}{r^2 - a^2 \cos^2 \theta} \right)$ $= \frac{p}{4\pi\epsilon_0 r^2} \left(\frac{\cos \theta}{1 - \frac{a^2}{r^2} \cos^2 \theta} \right)$ <p>For $r \gg a$, neglecting $\frac{a^2}{r^2}$</p> $V = \frac{p \cos \theta}{4\pi\epsilon_0 r^2}$	<p>$\frac{1}{2}$</p> <p>$\frac{1}{2}$</p> <p>$\frac{1}{2}$</p> <p>$\frac{1}{2}$</p>							
<p>(ii) Consider the side of equilateral triangle as 'a'</p> <p>Potential energy = $U = \frac{kq_1q_2}{a} + \frac{kq_2q_3}{a} + \frac{kq_1q_3}{a}$</p> <p>According to question</p> $U = \frac{k(q)(2q)}{a} + \frac{k(2q)(nq)}{a} + \frac{k(q)(nq)}{a} = 0$ $= \frac{2q^2}{a} + \frac{2nq^2}{a} + \frac{nq^2}{a} = 0$ $2 + 2n + n = 0$ $3n = -2$ $n = -\frac{2}{3}$	<p>$\frac{1}{2}$</p> <p>$\frac{1}{2}$</p> <p>$\frac{1}{2}$</p>							
OR								
<p>(b)</p> <table border="1" style="width: 100%; border-collapse: collapse;"> <tbody> <tr> <td style="padding: 5px;">(i) Statement of Gauss's Law</td> <td style="text-align: right; padding: 5px;">1</td> </tr> <tr> <td style="padding: 5px;">Obtaining expression for electric field</td> <td style="text-align: right; padding: 5px;">2</td> </tr> <tr> <td style="padding: 5px;">(ii) Finding net force on electron</td> <td style="text-align: right; padding: 5px;">2</td> </tr> </tbody> </table>	(i) Statement of Gauss's Law	1	Obtaining expression for electric field	2	(ii) Finding net force on electron	2		
(i) Statement of Gauss's Law	1							
Obtaining expression for electric field	2							
(ii) Finding net force on electron	2							
<p>(i) Electric Flux through a closed surface is equal to $\frac{q}{\epsilon_0}$, where q is the total charge enclosed by the surface. $\phi = \frac{q}{\epsilon_0}$</p> <p>Alternatively</p> <p>The surface integral of electric field over a closed surface is $\frac{1}{\epsilon_0}$ times the total charge enclosed by the surface.</p> $\oint \vec{E} \cdot d\vec{S} = \frac{q}{\epsilon_0}$ <p>(Award $\frac{1}{2}$ mark for writing the formula only.)</p>	<p>1</p>							

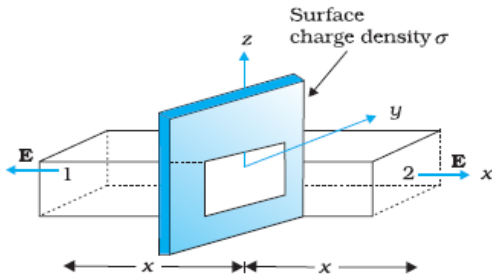

(Gaussian surface can be cylindrical also)

As seen from figure, only two faces 1 and 2 will contribute to the flux.

Flux $\vec{E} \cdot d\vec{s}$ through both the surfaces is equal and add up.

The charge enclosed by surface is σA , where σ is surface charge density

According to Gauss's theorem

$$2EA = \sigma A / \epsilon_0$$

$$E = \sigma / 2\epsilon_0$$

$$\vec{E} = \frac{\sigma}{2\epsilon_0} \hat{n} \quad \text{where } \hat{n} \text{ is unit vector directed normally out of the plane}$$

$$(ii) \vec{E} = \frac{\lambda}{2\pi\epsilon_0 r} \hat{r}$$

According to question

$$E_1 \text{ (at point P)} = \frac{\lambda_1}{2\pi\epsilon_0 r_1}$$

$$= \frac{10 \times 10^{-6}}{2\pi\epsilon_0 (10 \times 10^{-2})} (-\hat{j}) \text{ N/C}$$

$$E_2 \text{ (at point P)} = \frac{\lambda_2}{2\pi\epsilon_0 r_2}$$

$$= \frac{20 \times 10^{-6}}{2\pi\epsilon_0 (20 \times 10^{-2})} (-\hat{j}) \text{ N/C}$$

$$E_{net} = \frac{10 \times 10^{-6}}{2\pi\epsilon_0} \left(\frac{1}{0.1} + \frac{2}{0.2} \right) (-\hat{j}) \text{ N/C}$$

$$= 3.6 \times 10^6 (-\hat{j}) \text{ N/C}$$

$$F_{net} = q \times E_{net}$$

$$= -1.6 \times 10^{-19} \times 3.6 \times 10^6 (-\hat{j}) \text{ N}$$

$$= 5.76 \times 10^{-13} \text{ N } (\hat{j})$$

1/2

1/2

1/2

1/2

1/2

1/2

1/2

1/2

5

33.

(a)

(i) Showing helical path	1 1/2
Obtaining frequency of revolution	1 1/2
(ii) Finding magnetic moment of electron	2

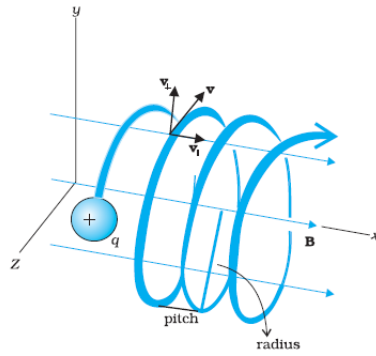

1/2

$v_{\perp} = v \sin \theta$ is perpendicular to \vec{B} and

$v_{\parallel} = v \cos \theta$ is parallel to \vec{B}

Due to v_{\perp} the charge describes circular path and v_{\parallel} pushes it in the direction of \vec{B} . Therefore under the combined effect of two components the charged particle describes helical path, as shown in the figure.

1

The centripetal force

$$\frac{mv_{\perp}^2}{r} = Bqv_{\perp}$$

1/2

$$v_{\perp} = \frac{Bqr}{m} \quad (v_{\perp} = v \sin \theta)$$

1/2

$$\begin{aligned} \text{Time period} = T &= \frac{2\pi r}{v_{\perp}} \\ &= \frac{2\pi m}{Bq} \end{aligned}$$

$$\text{frequency } \nu = \frac{1}{T} = \frac{Bq}{2\pi m}$$

1/2

(ii) Magnetic moment $m = IA$

$$I = \frac{e}{T} = ev$$

1/2

$$= 1.6 \times 10^{-19} \times 8 \times 10^{14}$$

$$= 1.28 \times 10^{-4} A$$

1/2

$$M = 1.28 \times 10^{-4} \times 3.14 \times (2 \times 10^{-10})^2$$

1/2

$$= 5.12\pi \times 10^{-24} Am^2 = 1.6 \times 10^{-23} Am^2$$

1/2

OR

(b)

(i) Definition of current sensitivity	1
Showing dependence of current sensitivity & explanation	1+1
(ii) Calculation of resistance	2

(i) Deflection produced per unit current is called its current sensitivity.

1

$$I_s = \frac{\theta}{I} = \frac{NBA}{K}$$

Current sensitivity can be increased by

(a) increasing number of turns in coil

<p>(b) increasing area of coil in magnetic field (c) decreasing K (Torsional Constant) (any one) $V_s = \frac{\theta}{V} = \frac{NBA}{KR}$ <p>If current sensitivity is increased by increasing number of turns of the coil, the resistance of the galvanometer will also increase. Thus voltage sensitivity may not increase.</p> <p>(ii) $V = I_G(R + G)$ $R = \frac{V}{I_G} - G$ $= \frac{100}{20 \times 10^{-3}} - 15$ $= 5000 - 15$ $= 4985 \Omega$ <p>By connecting 4985Ω in series with galvanometer it is converted to voltmeter of range (0-100V)</p> </p></p>	<p>1</p> <p>1</p> <p>$\frac{1}{2}$</p> <p>$\frac{1}{2}$</p> <p>$\frac{1}{2}$</p> <p>$\frac{1}{2}$</p>	<p>5</p>
--	---	-----------------