

**Marking Scheme**  
**Strictly Confidential**  
**(For Internal and Restricted use only)**  
**Senior School Certificate Examination, 2023**  
**SUBJECT : PHYSICS (042) (PAPER CODE 55/5/2)**

**General Instructions: -**

<b>1</b>	You are aware that evaluation is the most important process in the actual and correct assessment of the candidates. A small mistake in evaluation may lead to serious problems which may affect the future of the candidates, education system and teaching profession. To avoid mistakes, it is requested that before starting evaluation, you must read and understand the spot evaluation guidelines carefully.
<b>2</b>	<b>“Evaluation policy is a confidential policy as it is related to the confidentiality of the examinations conducted, Evaluation done and several other aspects. Its’ leakage to public in any manner could lead to derailment of the examination system and affect the life and future of millions of candidates. Sharing this policy/document to anyone, publishing in any magazine and printing in News Paper/Website etc may invite action under various rules of the Board and IPC.”</b>
<b>3</b>	Evaluation is to be done as per instructions provided in the Marking Scheme. It should not be done according to one’s own interpretation or any other consideration. Marking Scheme should be strictly adhered to and religiously followed. <b>However, while evaluating, answers which are based on latest information or knowledge and/or are innovative, they may be assessed for their correctness otherwise and due marks be awarded to them. In class-X, while evaluating two competency-based questions, please try to understand given answer and even if reply is not from marking scheme but correct competency is enumerated by the candidate, due marks should be awarded.</b>
<b>4</b>	The Marking scheme carries only suggested value points for the answers These are in the nature of Guidelines only and do not constitute the complete answer. The students can have their own expression and if the expression is correct, the due marks should be awarded accordingly.
<b>5</b>	The Head-Examiner must go through the first five answer books evaluated by each evaluator on the first day, to ensure that evaluation has been carried out as per the instructions given in the Marking Scheme. If there is any variation, the same should be zero after deliberation and discussion. The remaining answer books meant for evaluation shall be given only after ensuring that there is no significant variation in the marking of individual evaluators.
<b>6</b>	Evaluators will mark( √ ) wherever answer is correct. For wrong answer CROSS ‘X’ be marked. Evaluators will not put right ( ✓ )while evaluating which gives an impression that answer is correct and no marks are awarded. <b>This is most common mistake which evaluators are committing.</b>
<b>7</b>	If a question has parts, please award marks on the right-hand side for each part. Marks awarded for different parts of the question should then be totaled up and written in the left-hand margin and encircled. This may be followed strictly.
<b>8</b>	If a question does not have any parts, marks must be awarded in the left-hand margin and encircled. This may also be followed strictly.
<b>9</b>	If a student has attempted an extra question, answer of the question deserving more marks should be retained and the other answer scored out with a note <b>“Extra Question”</b> .

10	No marks to be deducted for the cumulative effect of an error. It should be penalized only once.
11	A full scale of marks 0 to 70 (example 0 to 80/70/60/50/40/30 marks as given in Question Paper) has to be used. Please do not hesitate to award full marks if the answer deserves it.
12	Every examiner has to necessarily do evaluation work for full working hours i.e., 8 hours every day and evaluate 20 answer books per day in main subjects and 25 answer books per day in other subjects (Details are given in Spot Guidelines). This is in view of the reduced syllabus and number of questions in question paper.
13	<p>Ensure that you do not make the following common types of errors committed by the Examiner in the past:-</p> <ul style="list-style-type: none"> <li>● Leaving answer or part thereof unassessed in an answer book.</li> <li>● Giving more marks for an answer than assigned to it.</li> <li>● Wrong totaling of marks awarded on an answer.</li> <li>● Wrong transfer of marks from the inside pages of the answer book to the title page.</li> <li>● Wrong question wise totaling on the title page.</li> <li>● Wrong totaling of marks of the two columns on the title page.</li> <li>● Wrong grand total.</li> <li>● Marks in words and figures not tallying/not same.</li> <li>● Wrong transfer of marks from the answer book to online award list.</li> <li>● Answers marked as correct, but marks not awarded. (Ensure that the right tick mark is correctly and clearly indicated. It should merely be a line. Same is with the X for incorrect answer.)</li> <li>● Half or a part of answer marked correct and the rest as wrong, but no marks awarded.</li> </ul>
14	While evaluating the answer books if the answer is found to be totally incorrect, it should be marked as cross (X) and awarded zero (0) Marks.
15	Any un assessed portion, non-carrying over of marks to the title page, or totaling error detected by the candidate shall damage the prestige of all the personnel engaged in the evaluation work as also of the Board. Hence, in order to uphold the prestige of all concerned, it is again reiterated that the instructions be followed meticulously and judiciously.
16	The Examiners should acquaint themselves with the guidelines given in the “ <b>Guidelines for spot Evaluation</b> ” before starting the actual evaluation.
17	Every Examiner shall also ensure that all the answers are evaluated, marks carried over to the title page, correctly totaled and written in figures and words.
18	The candidates are entitled to obtain photocopy of the Answer Book on request on payment of the prescribed processing fee. All Examiners/Additional Head Examiners/Head Examiners are once again reminded that they must ensure that evaluation is carried out strictly as per value points for each answer as given in the Marking Scheme.

**MARKING SCHEME: PHYSICS(042)**

Code:55/5/2

Q No.	VALUE POINTS/EXPECTED ANSWERS	Marks	Total Marks
<b>SECTION - A</b>			
1	(B) $\frac{Q}{6\epsilon_0}$	1	1
2	No option is correct. <b>[Award one mark to each student]</b>	1	1
3	(A) Copper	1	1
4	(D) 1.0 V	1	1
5	(C) $\lambda_{\text{radio waves}} > \lambda_{\text{microwaves}} > \lambda_{\text{visible}} > \lambda_{\text{X-rays}}$	1	1
6	(C) (i) remains constant, but (ii) increases	1	1
7	(B) $hc/\lambda$	1	1
8	(D) 1	1	1
9	(D) Diffusion current remains almost constant but drift current increases till both currents become equal.	1	1
10	(A) I	1	1
11	(C) $\frac{hc}{e}$	1	1
12	(C) Two of them connected in series and the combination in parallel to the third	1	1
13	(D) lags voltage in phase by $\frac{\pi}{2}$	1	1
14	(B) Maximum in the forward direction and zero in the backward direction.	1	1
15	(A) $n^2$	1	1
16	(A) Both assertion (A) and reason (R) are true and (R) is the correct explanation of (A)	1	1
17	(C) Assertion (A) is true and reason (R) is false	1	1
18	(C) Assertion (A) is true and reason (R) is false	1	1
<b>SECTION-B</b>			
19	<div style="border: 1px solid black; padding: 10px;"> <ul style="list-style-type: none"> <li>• Graph between potential energy and separation between the nucleons <span style="float: right;">(1)</span></li> <li>• For indicating region of graph                             <ul style="list-style-type: none"> <li>(a) For attractive nuclear force <span style="float: right;">(½)</span></li> <li>(b) For repulsive nuclear force <span style="float: right;">(½)</span></li> </ul> </li> </ul> </div>		

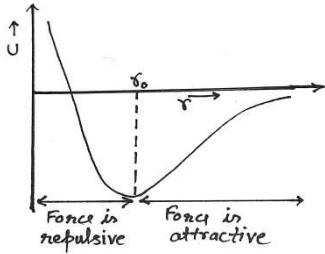
	 <p>Repulsive nuclear force for <math>r &lt; r_0</math>  Attractive force for <math>r &gt; r_0</math>  (Note- If student draws a graph without indicating the region of attractive and repulsive force, give 1 mark.)</p>	<p style="text-align: center;"><b>1</b></p> <p style="text-align: center;"><math>\frac{1}{2}</math></p> <p style="text-align: center;"><math>\frac{1}{2}</math></p>	<p style="text-align: center;"><b>2</b></p>
<p>20</p>	<p>(a)</p> <div style="border: 1px solid black; padding: 5px; margin-bottom: 10px;"> <p>(i) Effect of velocity of electron on de- Broglie wavelength <math>(\frac{1}{2})</math>  Justification <math>(\frac{1}{2})</math></p> <p>(ii) Effect of accelerating potential on de- Broglie wavelength <math>(\frac{1}{2})</math>  Justification <math>(\frac{1}{2})</math></p> </div> <p>(i) <math>\lambda = h/mv</math></p> <p>With decrease in velocity, de- Broglie wavelength increases</p> <p>(ii) <math>\lambda = \frac{h}{\sqrt{2meV}}</math></p> <p>With increase in accelerating potential, de- Broglie wavelength decreases</p> <p style="text-align: center;"><b>OR</b></p> <p>(b)</p> <div style="border: 1px solid black; padding: 5px; margin-bottom: 10px;"> <p>(i) Effect of frequency of incident radiation on stopping potential <math>(\frac{1}{2})</math>  Justification <math>(\frac{1}{2})</math></p> <p>(ii) Effect of intensity of incident radiation on stopping potential <math>(\frac{1}{2})</math>  Justification <math>(\frac{1}{2})</math></p> </div> <p>(i) With increase in frequency stopping potential will increase.</p> $V_0 = \frac{h}{e} \nu - \frac{\phi_0}{e}$ <p>(ii) Stopping potential remains same.  Energy of photoelectron ejected is independent of intensity of radiation</p>	<p style="text-align: center;"><math>\frac{1}{2}</math></p> <p style="text-align: center;"><math>\frac{1}{2}</math></p> <p style="text-align: center;"><math>\frac{1}{2}</math></p> <p style="text-align: center;"><math>\frac{1}{2}</math></p> <p style="text-align: center;"><math>\frac{1}{2}</math></p> <p style="text-align: center;"><math>\frac{1}{2}</math></p> <p style="text-align: center;"><math>\frac{1}{2}</math></p> <p style="text-align: center;"><math>\frac{1}{2}</math></p>	<p style="text-align: center;"><b>2</b></p>

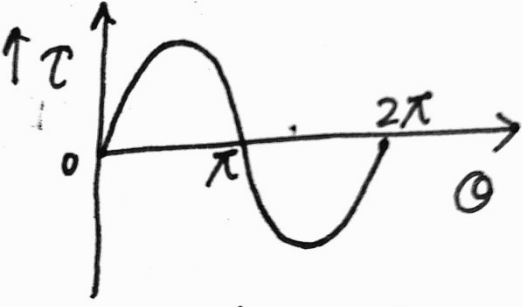
21	<div style="border: 1px solid black; padding: 5px; margin-bottom: 10px;"> <p>Identification (½)  Wavelength range (½)  Two sources (½) + (½)</p> </div> <p>Ultraviolet rays  Wavelength range <math>4 \times 10^{-7} \text{ m} - 6 \times 10^{-10} \text{ m}</math>  Sources :  1. The Sun  2. Any device in which inner shell electrons in atoms move from one energy level to a lower level.  (Any other relevant source)</p>	½ ½ ½ ½	2
22	<div style="border: 1px solid black; padding: 5px; margin-bottom: 10px;"> <p>(a) Graphical representation of torque - <math>\theta</math> (1)  Finding the orientation for  (i) Zero torque (½)  (ii) Maximum torque (½)</p> </div> <div style="text-align: center; margin-bottom: 10px;">  </div> <p>(i) Torque is zero for orientation corresponding to <math>\theta = 0^\circ</math> and <math>\theta = 180^\circ</math>  (ii) Torque is maximum for orientation corresponding to <math>\theta = \frac{\pi}{2}</math> and <math>\frac{3\pi}{2}</math>  (Note: Award full credit of 1 mark for parts (i) and (ii) if a student writes only one value of angle in each case.)</p>	1 ½ ½	2
23	<p>(a)</p> <div style="border: 1px solid black; padding: 5px; margin-bottom: 10px;"> <p>Expression for Lorentz force (½)  Condition for maximum magnitude of force (½)  Showing no work done in moving the charge from point <math>\vec{r}_1</math> to <math>\vec{r}_2</math> (1)</p> </div> <p><math display="block">\vec{F}_m = q(\vec{v} \times \vec{B})</math></p> <p><math display="block">F_m = qvB \sin \theta \quad (\because \vec{v} \perp \vec{B})</math></p>	½	

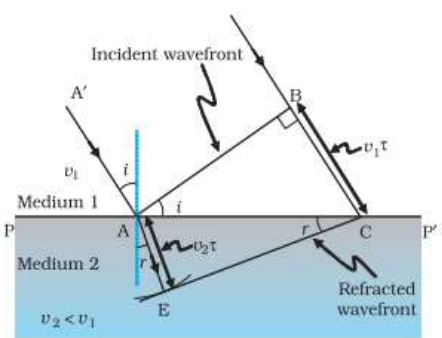

	$J = \frac{I}{A} = \frac{V}{RA}$ $J' = \frac{J}{2}$	1/2	2
25	<div style="border: 1px solid black; padding: 5px;"> <p>(i) Finding mutual inductance (1)</p> <p>(ii) Finding <math>\frac{dI_1}{dt}</math> (1)</p> </div> <p>(i) <math>\phi_2 = MI_1</math>  Slope of the graph, <math>M = \frac{\phi_2}{I_1}</math>  <math>M = 2.5 \text{ H}</math></p> <p>(ii) <math> \epsilon_2  = M \frac{dI_1}{dt}</math></p> $\frac{dI_1}{dt} = \frac{ \epsilon_2 }{M} = \frac{100}{2.5} = 40 \text{ As}^{-1}$	1/2  1/2  1/2	2
<b>SECTION-C</b>			
26	<div style="border: 1px solid black; padding: 5px;"> <p>(a) Tracing the refractive wavefront (1)</p> <p>Verification of Snell's Law of refraction (2)</p> </div>  <p>AB is incident wavefront, incident at an angle <math>i</math>. let <math>\tau</math> be the time taken by wavefront to travel distance BC.  <math>BC = v_1 \tau</math> where <math>v_1</math> is speed of wave in medium 1  To determine shape of refracted wavefront, we draw a sphere of radius <math>v_2 \tau</math>,</p>	1	

where  $v_2$  is speed of wave in medium 2.  
 CE represents a tangent drawn from point C on sphere, CE is the refracted wavefront.

$$\sin i = \frac{BC}{AC} = \frac{v_1 \tau}{AC} \quad \text{and}$$

$$\sin r = \frac{AE}{AC} = \frac{v_2 \tau}{AC}$$

Where  $i$  and  $r$  are the angles of incidence and refraction, respectively.

$$\frac{\sin i}{\sin r} = \frac{v_1}{v_2} = \frac{\mu_2}{\mu_1}$$

$$\mu_1 \sin i = \mu_2 \sin r$$

This is the Snell's law of refraction.

**OR**

Diagram showing the reflection of plane wave (1)  
 Verification of Law of reflection (2)

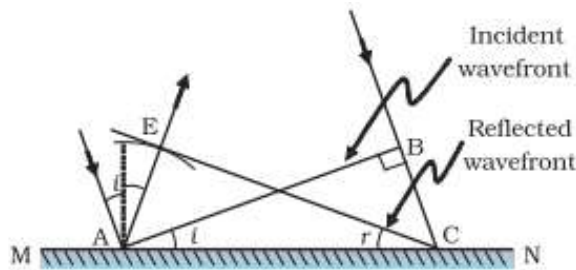

Consider a plane wave AB incident at an angle  $i$  on a reflecting surface MN.  
 If  $v$  is the speed of the wave in the medium and if  $\tau$  represents the time taken by the wavefront to advance from the point B to C then the distance  $BC = v \tau$

In order to construct the reflected wavefront, draw a sphere of radius  $v \tau$  from the point A. Let CE represent the tangent plane, drawn from the point C to this sphere.

In  $\triangle AEC$  and  $\triangle ABC$

$$AE = BC = v \tau$$

$$\angle CEA = \angle ABC \quad (90^\circ \text{ each})$$

AC is common side

$$\triangle AEC \cong \triangle ABC$$

$$\therefore \angle i = \angle r$$

This is the law of reflection.

1/2

1/2

1/2

1/2

1

1/2

1/2

1/2

1/2

3

27	<div style="border: 1px solid black; padding: 5px; margin-bottom: 10px;"> <p><b>Finding</b></p> <p>(i) Impedance of circuit (1)</p> <p>(ii) Self-inductance of coil (1)</p> <p>(iii) Phase difference between voltage and current (1)</p> </div> <p>(i) Impedance <math>Z = \frac{V_{rms}}{I_{rms}}</math></p> $Z = \frac{100}{0.5}$ $Z = 200 \Omega$ <p>(ii) <math>Z^2 = X_L^2 + R^2</math></p> $\text{Resistance } R = \frac{V_{rms}}{I_{rms}} = \frac{100}{1} = 100 \Omega$ $(X_L)^2 = Z^2 - R^2$ $= (200)^2 - (100)^2$ $X_L = 100\sqrt{3}$ $\omega L = 100\sqrt{3}$ $100L = 100\sqrt{3}$ $\Rightarrow L = \sqrt{3}H$ <p>(iii) Phase difference</p> $\tan \phi = \frac{X_L}{R}$ $= \frac{100\sqrt{3}}{100} = \sqrt{3}$ $\Rightarrow \phi = 60^\circ$	<p>1/2</p> <p>1/2</p> <p>1/2</p> <p>1/2</p> <p>1/2</p> <p>1/2</p>	<p>3</p>
28	<div style="border: 1px solid black; padding: 5px; margin-bottom: 10px;"> <p>Obtaining an expression for voltage in secondary coil (2)</p> <p>Two main sources of power loss (1/2 + 1/2)</p> </div> <p>When alternating voltage <math>V_p</math> is supplied to the primary coil, an emf is induced in this coil.</p> $\epsilon_p = -N_p \frac{d\phi}{dt} = V_p$ <p>Which causes an induced emf in secondary coil</p> $\epsilon_s = -N_s \frac{d\phi}{dt}$	<p>1/2</p> <p>1/2</p>	

	<p>If the current taken from the secondary coil is small i.e secondary is an open circuit than <math>\epsilon_s = V_s</math></p> $V_s = -N_s \frac{d\phi}{dt}$ $\Rightarrow V_s = \frac{N_s}{N_p} \times V_p$ <p>Two main sources of power loss</p> <ol style="list-style-type: none"> <li>1. Flux leakage</li> <li>2. Resistance of the windings</li> <li>3. Eddy currents</li> <li>4. Hysteresis</li> </ol> <p><b>(Any two)</b></p>	<p><math>\frac{1}{2}</math></p> <p><math>\frac{1}{2}</math></p> <p><math>\frac{1}{2} + \frac{1}{2}</math></p>	<p><b>3</b></p>
<p>29</p>	<div style="border: 1px solid black; padding: 5px; margin-bottom: 10px;"> <p>(a) Methods to increase current sensitivity of moving coil galvanometer (1)</p> <p>(b) Calculation of resistance of galvanometer (2)</p> </div> <p>(a) Current sensitivity of moving coil galvanometer can be increased by</p> <ol style="list-style-type: none"> <li>(1) increasing number of turns in the coil (<math>I_s \propto N</math>)</li> <li>(2) increasing magnetic field strength (<math>I_s \propto B</math>)</li> <li>(3) using a material having lesser value of torsional constant (<math>I_s \propto \frac{1}{k}</math>)</li> <li>(4) increasing area of cross-section of the coil</li> </ol> <p>( Note- Any one of the above )</p> <p>(b) <math>R = \frac{V}{I_g} - G</math>  For range (0-V)  <math>R_1 = \frac{V}{I_g} - G</math>-----(1)  For range (0-2V)  <math>R_2 = \frac{2V}{I_g} - G</math>-----(2)  On solving equations (1) and (2)  <math>G = R_2 - 2R_1</math></p>	<p><b>1</b></p> <p><math>\frac{1}{2}</math></p> <p><math>\frac{1}{2}</math></p> <p><math>\frac{1}{2}</math></p> <p><math>\frac{1}{2}</math></p>	<p><b>3</b></p>

30	<p>(a)</p> <div style="border: 1px solid black; padding: 5px; margin-bottom: 10px;"> <p>(i) Limitations of Rutherford's model of atom (1)</p> <p>(ii) Calculation of wavelength of first line of Balmer Series (2)</p> </div> <p>(i) 1. Rutherford Model was unable to explain the stability of atom. 2. It could not explain the existence of the line spectrum.</p> <p>(ii) <math>\frac{1}{\lambda} = R \left[ \frac{1}{n_i^2} - \frac{1}{n_f^2} \right]</math>  <math>\frac{1}{\lambda_2} = R \left[ \frac{1}{2^2} - \frac{1}{4^2} \right]</math>  <math>\frac{1}{\lambda_2} = \frac{3R}{16}</math> -----(i)</p> $\frac{1}{\lambda_1} = R \left[ \frac{1}{2^2} - \frac{1}{3^2} \right]$ $\frac{1}{\lambda_1} = \frac{5R}{36}$ -----(ii) $\frac{\lambda_1}{\lambda_2} = \frac{36}{5R} \frac{3R}{16}$ $\lambda_1 = \frac{36 \times 3}{5 \times 16} \times 4861$ $\lambda_1 = 6562.35 \text{ \AA}$ <p style="text-align: center;"><b>OR</b></p> <p>(b)</p> <div style="border: 1px solid black; padding: 5px; margin-bottom: 10px;"> <p>(i) Explanation of independency (1)</p> <p>(ii) Calculation of work function (2)</p> </div> <p>(i)  <math>h\nu = \phi_o + K_{\max}</math>  It is evident from the above equation that the maximum kinetic energy depends on the frequency of incident radiation and is independent of the intensity of the radiations.</p> <p>(ii) Energy carried by the photon</p>	<p><math>\frac{1}{2}</math></p> <p><math>\frac{1}{2}</math></p> <p><math>\frac{1}{2}</math></p> <p><math>\frac{1}{2}</math></p> <p><math>\frac{1}{2}</math></p> <p><math>\frac{1}{2}</math></p> <p><math>\frac{1}{2}</math></p> <p><math>\frac{1}{2}</math></p> <p><math>\frac{1}{2}</math></p> <p><math>\frac{1}{2}</math></p> <p><math>\frac{1}{2}</math></p> <p><math>\frac{1}{2}</math></p> <p><math>\frac{1}{2}</math></p> <p><math>\frac{1}{2}</math></p> <p><math>\frac{1}{2}</math></p> <p><math>\frac{1}{2}</math></p> <p><math>\frac{1}{2}</math></p> <p><math>\frac{1}{2}</math></p> <p><math>\frac{1}{2}</math></p> <p><math>\frac{1}{2}</math></p> <p><math>\frac{1}{2}</math></p>	
----	--	---	--

$$E = E_i - E_f$$

$$E = -\frac{13.6}{2^2} - \left( \frac{-13.6}{1^2} \right) = 10.2 \text{ eV}$$

$$\phi_o = E - eV_o$$

$$= 10.2 \text{ eV} - 5 \text{ eV}$$

$$= 5.2 \text{ eV}$$

½

½

½

3

**SECTION D**

31

(a)

Circuit arrangement for V-I characteristics of p-n junction in

- (i) forward bias (1)
- (ii) reverse bias (1)

V-I characteristics (1)

Explanation of

- (i) Minority carrier injection in forward bias (1)
- (ii) Breakdown Voltage in reverse bias (1)

(i)

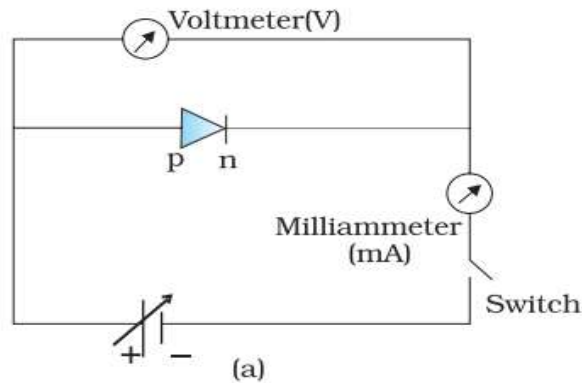

1

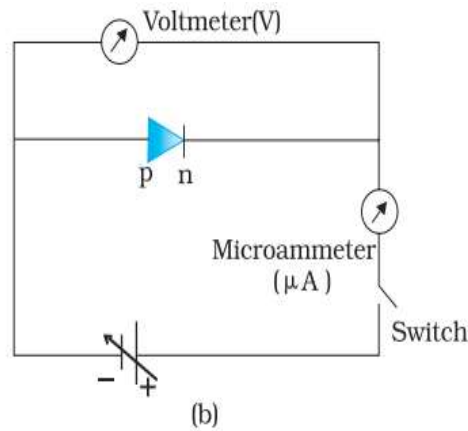

1

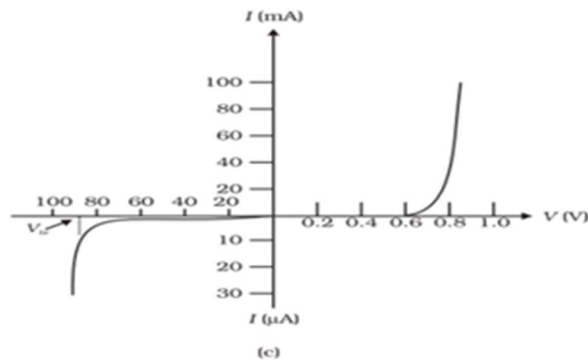

1

(Note: Do not deduct marks for not showing values.)

**Minority carrier injection:** Under forward bias electrons from n-side cross the depletion region and reach p-side. Similarly, holes from p-side cross the junction and reach the n-side.

1

**Breakdown voltage:** It is the voltage under reverse bias for which reverse current increases sharply

1

OR

(b)	Naming two important processes	( $\frac{1}{2} + \frac{1}{2}$ )
	Circuit diagram	(1)
	Working of junction diode as a full wave rectifier	(1)
	Input & output waveforms	(1)
	Characteristics / Property	(1)

(a) Diffusion  
Drift

$\frac{1}{2}$

$\frac{1}{2}$

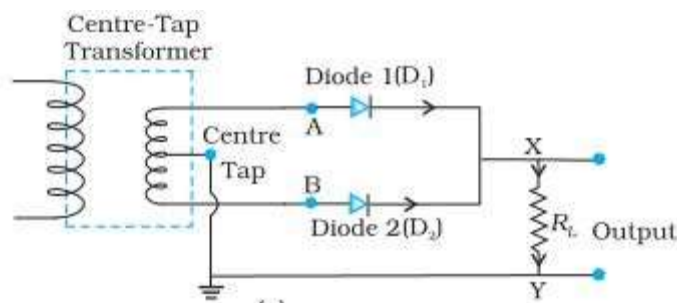

1

Suppose the input voltage to A with respect to the centre-tap at any instant is

positive. At that instant, voltage at B being out of phase will be negative. So, diode  $D_1$  gets forward biased and conducts (while  $D_2$  being reverse biased is not conducting). Hence, during this positive half cycle we get an output current (and a output voltage across the load resistor  $R_L$ ). In the course of ac cycle when the voltage at A becomes negative with respect to centre tap, the voltage at B would be positive. In this part of the cycle diode  $D_1$  would not conduct but diode  $D_2$  would, giving an output current and output voltage (across  $R_L$ ) during the negative half cycle of the input ac.

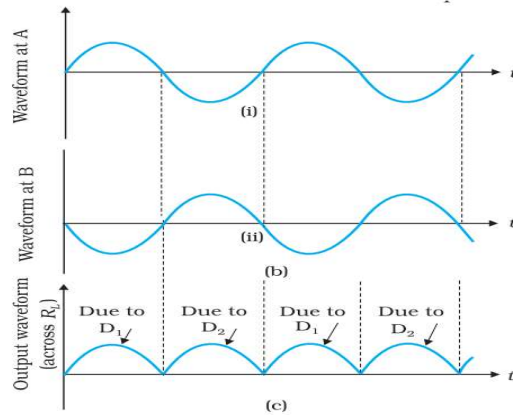

**Property** Junction diode allows current to pass only when it is forward biased.

1

$\frac{1}{2}$

$\frac{1}{2}$

1

5

32

(a)

- |   |      |
|---|------|
| (i) Ray diagram of compound microscope.         | (1½) |
| Expression for total magnification              | (1½) |
| (ii) Finding the magnifying power of microscope | (2)  |

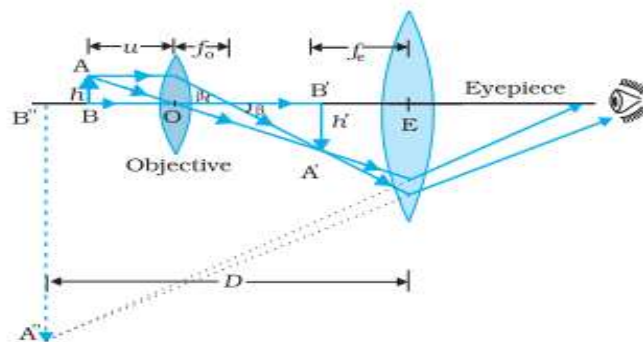

**(Note:** Give full credit of the diagram, if a student draws diagram for normal adjustment.  
Deduct  $\frac{1}{2}$  mark for not showing the direction of propagation of

$\frac{1}{2}$

	<p>light.)</p> <p>Linear magnification due to the objective is</p> $\tan \beta = \left( \frac{h}{f_0} \right) = \left( \frac{h'}{L} \right)$ $m_0 = \frac{h'}{h} = \frac{L}{f_0}$ <p>Here L is the distance between the second focal point of the objective and the first focal point of the eyepiece.</p> <p>Linear magnification due to eyepiece is</p> $m_e = \left( 1 + \frac{D}{f_e} \right)$ <p>Thus, the total magnification is, <math>m = m_0 \times m_e</math></p> $m = \frac{L}{f_0} \left( 1 + \frac{D}{f_e} \right)$ <p><b>Note:</b> full credit of the derivation should be given if a student derives</p> $m = \frac{v_0}{u_0} \left( 1 + \frac{D}{f_e} \right)$ <p>(ii) Given:</p> <p><math>u_0 = -1.5 \text{ cm}</math></p> <p><math>f_0 = 1.25 \text{ cm}</math></p> <p><math>f_e = 5 \text{ cm}</math></p> <p><math>D = 25 \text{ cm}</math></p> $\frac{1}{f_0} = \frac{1}{v_0} - \frac{1}{u_0}$ $\frac{1}{1.25} = \frac{1}{v_0} - \frac{1}{-1.5} = \frac{2}{15}$ $v_0 = \frac{15}{2} \text{ cm}$ $ m_0  = \frac{v_0}{u_0} = \frac{15}{2} \times \frac{1}{1.5} = 5$ $ m_e  = \left( 1 + \frac{D}{f_e} \right)$	<p><math>\frac{1}{2}</math></p> <p><math>\frac{1}{2}</math></p> <p><math>\frac{1}{2}</math></p> <p><math>\frac{1}{2}</math></p> <p><math>\frac{1}{2}</math></p> <p><math>\frac{1}{2}</math></p>	
--	--	---	--

$$|m_e| = 1 + \frac{25}{5} = 6$$

$$m = m_o \times m_e = 5 \times 6 = 30$$

OR

- |   |       |
|---|-------|
| (i) Ray diagram for image formation by astronomical telescope in normal adjustment. | (1½)  |
| Expression for magnifying power   | (1½)  |
| (ii) Formula  | (½+½) |
| Calculation of focal length of both lenses  | (½+½) |

(i)

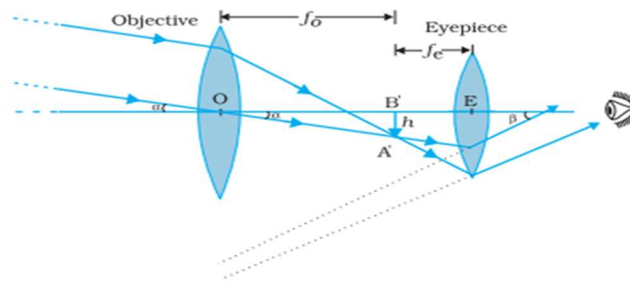

**Magnifying power (m)**

$$m \approx \frac{\beta}{\alpha}$$

$$\beta = \frac{h}{f_e}$$

$$\alpha = \frac{h}{f_o}$$

$$m = \frac{f_o}{f_e}$$

(ii)  $m = 2.9$ ,  $d = 150$  cm (Given)

$$m = \frac{f_o}{f_e} = \frac{29}{10}$$

$$f_o + f_e = 150$$

$$f_e = 38.5$$
 cm

$$f_o = 150 - 38.5 = 111.5$$
 cm

½

½

1½

½

½

½

½

½

½

½

**5**

33

(a)

- |   |     |
|---|-----|
| (i) Explanation                           | (1) |
| Obtaining expression for average velocity | (2) |
| (ii) Finding ratio of drift velocities    | (2) |

	<p>(a) (i) Under the effect of external field, an electron experiences a force <math>\vec{F} = -e\vec{E}</math> between collisions</p> <p>Due to this force the electron is accelerated and attains a velocity. This velocity is different for different electrons, which averaged over all electrons gives average drift velocity. This drift velocity is constant for a given temperature.</p> <p><b>Expression of average velocity:</b></p> <p>Under the action of an electric field electrons get accelerated with <math>a = -\frac{eE}{m}</math></p> <p>Velocity of an electron at any instant of time is</p> $\vec{V}_i = \vec{v}_i - \frac{e\vec{E}}{m}t_i$ <p>Average velocity of the electrons at time 't' is the drift velocity</p> $\vec{v}_d = (\vec{V}_i)_{average}$ $(\vec{V}_i)_{average} = (\vec{v}_i)_{average} - \frac{e\vec{E}}{m}(t_i)_{average}$ <p>But <math>(\vec{v}_i)_{average} = 0</math> due to randomness</p> $\vec{v}_d = 0 - \frac{e\vec{E}}{m}\tau$ $\vec{v}_d = -\frac{e\vec{E}}{m}\tau$ <p>(ii) <math>v_d = \frac{I}{enA} = \left(\frac{4I}{e\pi D^2}\right) \times \frac{1}{n}</math></p> <p><math>v_d \propto \frac{1}{n}</math> for same diameter and current</p> <p><math>n_A = 1.5n_B</math> (Given)</p> $\frac{v_{dA}}{v_{dB}} = \frac{n_B}{n_A} = \frac{2}{3}$	<p style="text-align: center;"><b>1</b></p> <p style="text-align: center;"><math>\frac{1}{2}</math></p> <p style="text-align: center;"><math>\frac{1}{2}</math></p> <p style="text-align: center;"><math>\frac{1}{2}</math></p> <p style="text-align: center;"><math>\frac{1}{2}</math></p> <p style="text-align: center;"><math>\frac{1}{2}</math></p> <p style="text-align: center;"><math>\frac{1}{2}</math></p> <p style="text-align: center;"><b>1</b></p>	
--	--	---	--

OR

- (b)
- (i)
    - i Plot showing variation of  $V$  with  $R$  (1)
    - ii Plot showing variation of  $V$  with  $I$  (1)
  - (ii)
    - (i) Obtaining expression for current flowing through circuit  $(1\frac{1}{2})$
    - (ii) Obtaining expression for terminal potential difference across the equivalent cell.  $(1\frac{1}{2})$

(i)

i.

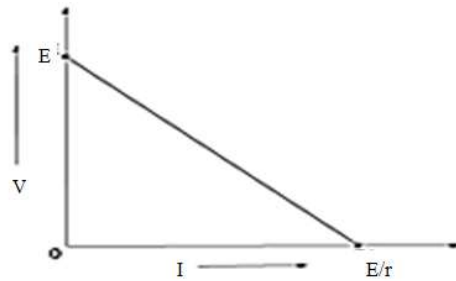

1

ii.

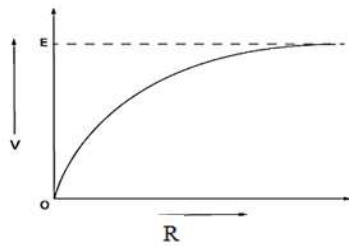

1

(ii)

$$\frac{1}{r_{eq}} = \frac{1}{r_1} + \frac{1}{r_2} + \frac{1}{r_3}$$

$$\frac{1}{r_{eq}} = \frac{1}{2r} + \frac{1}{3r} + \frac{1}{6r}$$

$$r_{eq} = r$$

$\frac{1}{2}$

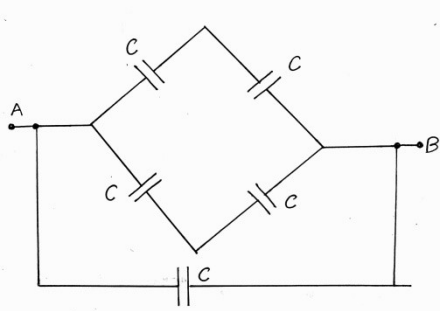
	<p>Given cells are of equal emf (<math>E</math>) and connected in parallel, so</p> $\frac{E_{eq}}{r_{eq}} = \frac{E}{2r} + \frac{E}{3r} + \frac{E}{6r}$ $E_{eq} = E$ <p>Current flowing <math>I = \frac{E_{eq}}{R + r_{eq}}</math></p> $I = \frac{E}{R + r}$ <p>The terminal potential difference</p> $V = E_{eq} - Ir_{eq}$ $V = E - \frac{E}{(R + r)} \times r$ $V = \frac{ER}{R + r}$	<p><math>\frac{1}{2}</math></p> <p><math>\frac{1}{2}</math></p> <p><math>\frac{1}{2}</math></p> <p><math>\frac{1}{2}</math></p> <p><math>\frac{1}{2}</math></p>	<p><b>5</b></p>
<b>SECTION E</b>			
<p>34</p>	<div style="border: 1px solid black; padding: 10px; margin-bottom: 10px;"> <p>(i) Calculation of equivalent capacitance (1)  (ii) Explanation of electric field reduction (1)  (iii) Finding the potential difference across the combination (1)  Finding the charge lost by capacitor A (1)  OR  Finding the capacitance of system (2)</p> </div> <p>(i)</p> 	<p><math>\frac{1}{2}</math></p>	

$C_{\text{net}} = C + C$ $= 2C$ <p>(Note: Give full credit to a student if 2C written directly)</p>	1/2	
<p>(ii) Within the dielectric slab, induced electric field due to polarization, decreases the electric field.</p> <p><b>Alternatively: <math>E = E_0 - E_p</math></b></p> <p><b>Alternatively: <math>E = \frac{E_0}{K}</math></b></p>	1	
<p>(iii)</p> <p>(a) <math display="block">V' = \frac{Q_{\text{Total}}}{C_{\text{eqi}}} = \frac{Q}{3C}</math></p>	1/2	
$V' = \frac{Q}{3C} = \frac{V}{3}$	1/2	
<p>(b)</p> $Q_A' = C \times \frac{V}{3} = \frac{Q}{3}$ $Q_A = CV = Q$	1/2	
<p>Charge lost by capacitor A is</p> $\Delta Q = Q - \frac{Q}{3} = \frac{2Q}{3}$	1/2	
<p><b>OR</b></p>		
<p>Capacitance of left portion, <math>C_1 = \frac{6K \epsilon_0 A}{d}</math></p>	1/2	
<p>Capacitance of right portion, <math>C_2 = \frac{3K \epsilon_0 A}{2d}</math></p>	1/2	
<p>As the capacitors are in series</p> $\frac{1}{C_{\text{eqi}}} = \frac{1}{C_1} + \frac{1}{C_2}$	1/2	

	$\frac{1}{C_{eqi}} = \frac{d}{6K \epsilon_o A} + \frac{2d}{3K \epsilon_o A} = \frac{5d}{6KA \epsilon_o}$ $C_{eqi} = \frac{6KA \epsilon_o}{5d}$	1/2	4
35	<div style="border: 1px solid black; padding: 5px; margin-bottom: 10px;"> <p>i) Answer and explanation (1/2 + 1/2)</p> <p>ii) Answer and explanation (1/2 + 1/2)</p> <p>iii) For finding radius of curvature (2)</p> <p style="text-align: center;"><b>OR</b></p> <p>Finding the separation between lenses (2)</p> </div> <p>(i) No, The lens is made up of two materials of different refractive indices. It has two focal lengths. 1/2</p> <p>(ii) Yes Rays are still intersecting/ converging at the location of image. 1/2</p> <p>(iii) <math>\frac{1}{f} = (n-1) \left[ \frac{1}{R_1} - \frac{1}{R_2} \right]</math> 1/2</p> <p style="margin-left: 40px;"><math>R_1 = +R, R_2 = -R</math> 1/2</p> <p style="margin-left: 40px;"><math>\frac{1}{f} = (n-1) \left[ \frac{2}{R} \right]</math> 1/2</p> <p style="margin-left: 40px;"><math>R = 2(n-1)f</math></p> <p style="margin-left: 40px;"><math>R = 2(1.55-1) \times 20 = 22 \text{ cm}</math> 1/2</p> <p style="text-align: center;">OR</p> <p style="margin-left: 40px;">For lens A (f=15 cm)</p> <p style="margin-left: 40px;"><math>u = -30 \text{ cm}</math></p> <p style="margin-left: 40px;"><math>\frac{1}{v} - \frac{1}{u} = \frac{1}{f}</math></p>		

