

Marking Scheme  
Strictly Confidential  
(For Internal and Restricted use only)  
Senior School Certificate Examination, 2024  
**SUBJECT PHYSICS (CODE 55/4/3)**

**General Instructions: -**

<b>1</b>	You are aware that evaluation is the most important process in the actual and correct assessment of the candidates. A small mistake in evaluation may lead to serious problems which may affect the future of the candidates, education system and teaching profession. To avoid mistakes, it is requested that before starting evaluation, you must read and understand the spot evaluation guidelines carefully.
<b>2</b>	<b>“Evaluation policy is a confidential policy as it is related to the confidentiality of the examinations conducted, Evaluation done and several other aspects. Its’ leakage to public in any manner could lead to derailment of the examination system and affect the life and future of millions of candidates. Sharing this policy/document to anyone, publishing in any magazine and printing in News Paper/Website etc may invite action under various rules of the Board and IPC.”</b>
<b>3</b>	Evaluation is to be done as per instructions provided in the Marking Scheme. It should not be done according to one’s own interpretation or any other consideration. Marking Scheme should be strictly adhered to and religiously followed. <b>However, while evaluating, answers which are based on latest information or knowledge and/or are innovative, they may be assessed for their correctness otherwise and due marks be awarded to them. In class-X, while evaluating two competency-based questions, please try to understand given answer and even if reply is not from marking scheme but correct competency is enumerated by the candidate, due marks should be awarded.</b>
<b>4</b>	The Marking scheme carries only suggested value points for the answers  These are in the nature of Guidelines only and do not constitute the complete answer. The students can have their own expression and if the expression is correct, the due marks should be awarded accordingly.
<b>5</b>	The Head-Examiner must go through the first five answer books evaluated by each evaluator on the first day, to ensure that evaluation has been carried out as per the instructions given in the Marking Scheme. If there is any variation, the same should be zero after deliberation and discussion. The remaining answer books meant for evaluation shall be given only after ensuring that there is no significant variation in the marking of individual evaluators.
<b>6</b>	Evaluators will mark( ✓ ) wherever answer is correct. For wrong answer CROSS ‘X’ be marked. Evaluators will not put right (✓)while evaluating which gives an impression that answer is correct and no marks are awarded. <b>This is most common mistake which evaluators are committing.</b>
<b>7</b>	If a question has parts, please award marks on the right-hand side for each part. Marks awarded for different parts of the question should then be totaled up and written in the left-hand margin and encircled. This may be followed strictly.
<b>8</b>	If a question does not have any parts, marks must be awarded in the left-hand margin and

	encircled. This may also be followed strictly.
9	If a student has attempted an extra question, answer of the question deserving more marks should be retained and the other answer scored out with a note “ <b>Extra Question</b> ”.
10	No marks to be deducted for the cumulative effect of an error. It should be penalized only once.
11	A full scale of marks 0 to 70_(example 0 to 80/70/60/50/40/30 marks as given in Question Paper) has to be used. Please do not hesitate to award full marks if the answer deserves it.
12	Every examiner has to necessarily do evaluation work for full working hours i.e., 8 hours every day and evaluate 20 answer books per day in main subjects and 25 answer books per day in other subjects (Details are given in Spot Guidelines). This is in view of the reduced syllabus and number of questions in question paper.
13	<p>Ensure that you do not make the following common types of errors committed by the Examiner in the past:-</p> <ul style="list-style-type: none"> <li>● Leaving answer or part thereof unassessed in an answer book.</li> <li>● Giving more marks for an answer than assigned to it.</li> <li>● Wrong totaling of marks awarded on an answer.</li> <li>● Wrong transfer of marks from the inside pages of the answer book to the title page.</li> <li>● Wrong question wise totaling on the title page.</li> <li>● Wrong totaling of marks of the two columns on the title page.</li> <li>● Wrong grand total.</li> <li>● Marks in words and figures not tallying/not same.</li> <li>● Wrong transfer of marks from the answer book to online award list.</li> <li>● Answers marked as correct, but marks not awarded. (Ensure that the right tick mark is correctly and clearly indicated. It should merely be a line. Same is with the X for incorrect answer.)</li> <li>● Half or a part of answer marked correct and the rest as wrong, but no marks awarded.</li> </ul>
14	While evaluating the answer books if the answer is found to be totally incorrect, it should be marked as cross (X) and awarded zero (0)Marks.
15	Any unassessed portion, non-carrying over of marks to the title page, or totaling error detected by the candidate shall damage the prestige of all the personnel engaged in the evaluation work as also of the Board. Hence, in order to uphold the prestige of all concerned, it is again reiterated that the instructions be followed meticulously and judiciously.
16	The Examiners should acquaint themselves with the guidelines given in the “ <b>Guidelines for Spot Evaluation</b> ” before starting the actual evaluation.
17	Every Examiner shall also ensure that all the answers are evaluated, marks carried over to the title page, correctly totaled and written in figures and words.
18	The candidates are entitled to obtain photocopy of the Answer Book on request on payment of the prescribed processing fee. All Examiners/Additional Head Examiners/Head Examiners are once again reminded that they must ensure that evaluation is carried out strictly as per value points for each answer as given in the Marking Scheme.

**MARKING SCHEME : PHYSICS (042)**

CODE : 55/4/3

Q.NO	VALUE POINTS/EXPECTED ANSWERS	MARKS	TOTAL MARKS				
<b>SECTION - A</b>							
1	( A ) 2 pE	1	1				
2	( B ) Repulsive and $\frac{q\lambda}{2\pi\epsilon_0 x}$	1	1				
3	( A ) Zero.	1	1				
4	( D ) Closer together and weaker in intensity.	1	1				
5	No option is correct, award 1 mark.	1	1				
6	No option is correct, award 1 mark.	1	1				
7	( A ) R	1	1				
8	( B ) 1mA	1	1				
9	( C ) $\frac{1}{\sqrt{2}}\sqrt{(i_1^2 + i_2^2)}$	1	1				
10	( A ) There is a minimum frequency of incident radiation below which no electrons are emitted.	1	1				
11	( A ) Small and negative.	1	1				
12	( C ) $r_n \propto n^2$	1	1				
13	( A ) Both assertion (A) and Reason ( R ) are true and Reason ( R ) is the correct explanation of Assertion(A).	1	1				
14	( C ) Assertion ( A ) is true and Reason ( R ) is false.	1	1				
15	( B ) Both assertion (A) and Reason ( R ) are true and Reason ( R ) is not the correct explanation of Assertion(A).	1	1				
16	( D ) Both Assertion (A) and Reason ( R ) are false.	1	1				
<b>SECTION - B</b>							
17	<p>(a) <table border="1" style="display: inline-table; vertical-align: middle;"><tr><td>Finding nature and position of image</td><td align="right">2</td></tr></table></p> <p>Using refraction formula at spherical surface from denser to rarer medium  <math>n_1</math> = refractive index of rarer medium  <math>n_2</math> = refractive index of denser medium</p> $\frac{n_1}{v} - \frac{n_2}{u} = \frac{n_1 - n_2}{R}$ <p><math>u = -20 \text{ cm}</math> , <math>R = -40 \text{ cm}</math> , <math>n_1 = 1</math> , <math>n_2 = 1.5</math></p> $\frac{1}{v} - \frac{1.5}{(-20)} = \frac{1 - 1.5}{(-40)}$ <p><math>v = -16 \text{ cm}</math>                      Nature of image is virtual.</p> <p align="center">OR</p> <p>(b) <table border="1" style="display: inline-table; vertical-align: middle;"><tr><td>Finding the focal lengths of the objective and eyepiece</td><td align="right">2</td></tr></table></p> <p>Distance between objective and eyepiece  <math>f_o + f_e = 1.00 \text{ m} = 100 \text{ cm}</math>                      Magnifying power</p> $ m  = \frac{f_o}{f_e} = 19$ <p>On solving  <math>f_o = 95 \text{ cm} = 0.95 \text{ m}</math>  <math>f_e = 5 \text{ cm} = 0.05 \text{ m}</math></p>	Finding nature and position of image	2	Finding the focal lengths of the objective and eyepiece	2	<p>1/2</p> <p>1/2</p> <p>1/2</p> <p>1/2</p> <p>1/2</p> <p>1/2</p> <p>1/2</p> <p>1/2</p>	<b>2</b>
Finding nature and position of image	2						
Finding the focal lengths of the objective and eyepiece	2						

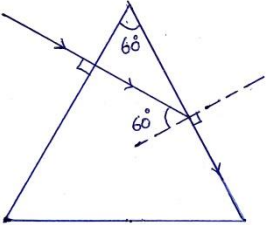
18	<div style="border: 1px solid black; padding: 5px; margin-bottom: 10px;">           Finding <math>\frac{V_p}{V_d}</math> <span style="float: right;">2</span> </div> <p>De Broglie wavelength of proton</p> $\lambda_p = \frac{h}{\sqrt{2meV_p}}$ <p>De Broglie wavelength of deuteron</p> $\lambda_d = \frac{h}{\sqrt{2(2m)eV_d}}$ $\frac{\lambda_p}{\lambda_d} = \frac{1}{2} = \frac{\sqrt{2(2m)eV_d}}{\sqrt{2meV_p}}$ <p>On solving</p> $\frac{V_p}{V_d} = 8$	$\frac{1}{2}$          $\frac{1}{2}$	          <b>2</b>
19	<div style="border: 1px solid black; padding: 5px; margin-bottom: 10px;">           Finding refractive index of the medium <span style="float: right;">2</span> </div>  <p>From snell's law, <math>\mu \cdot \sin i = \mu_m \cdot \sin r</math></p> $\mu \cdot \sin 60^\circ = \mu_m \cdot \sin 90^\circ$ $\mu_m = \mu \cdot \frac{\sqrt{3}}{2}$ <p><b>Alternatively</b></p> $\mu_{ga} = \frac{1}{\sin C}$ $\frac{\mu}{\mu_m} = \frac{1}{\sin 60^\circ}$ $\mu_m = \frac{\sqrt{3}}{2} \mu$	$\frac{1}{2}$          $\frac{1}{2}$          $\frac{1}{2}$	          <b>2</b>
20	<div style="border: 1px solid black; padding: 5px; margin-bottom: 10px;">           Finding temperature of conductor <span style="float: right;">2</span> </div> $R_2 = R_1 + 25\% \text{ of } R_1 = 1.25R_1$ <p>Temperature coefficient of resistance</p> $\alpha = \frac{R_2 - R_1}{R_1 \cdot \Delta T}$ $T_2 - 27 = \frac{1.25R_1 - R_1}{R_1 \times 2 \times 10^{-4}}$ $T_2 = 1277^\circ \text{C}$	$\frac{1}{2}$          $\frac{1}{2}$          $\frac{1}{2}$	          <b>2</b>

21

Drawing of circuit diagram of p-n junction diode

- (i) Forward bias 1/2
- (ii) Reverse bias 1/2
- I-V characteristics in forward and reverse bias 1/2 + 1/2

(i)

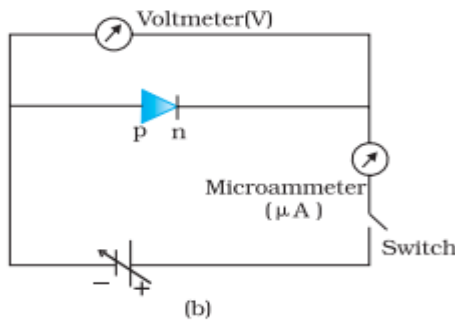
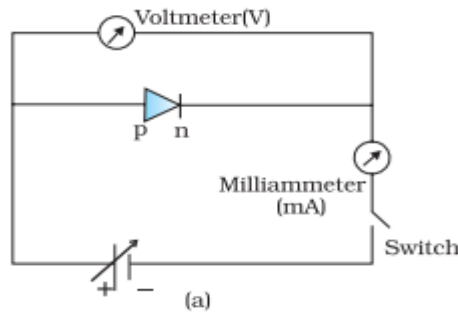

I-V characteristics in forward and reverse bias

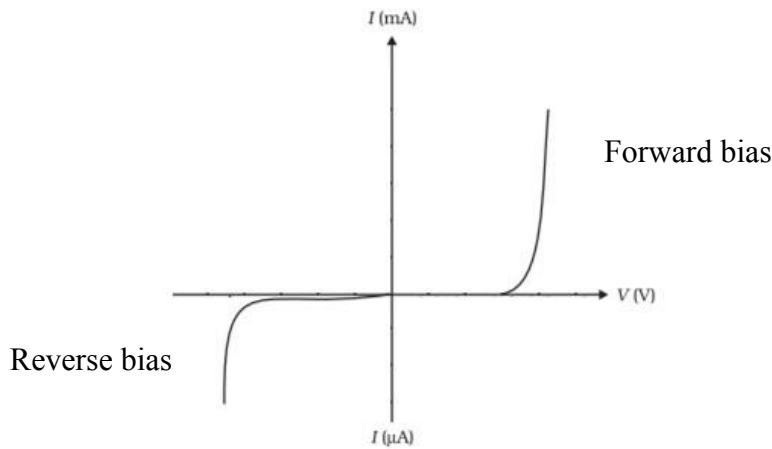

1/2

1/2

1/2 + 1/2

2

**SECTION - C**

22

(a)

- (i) Defining mutual inductance 1/2
- SI unit of mutual inductance 1/2
- (ii) Deriving expression for mutual inductance 2

(i) Mutual inductance between two coils is defined as the magnetic flux associated with a coil when unit current flows through neighbouring coil.

**Alternatively**

Mutual inductance between two coils is defined as the magnitude of induced emf in a coil when the rate of change of current in neighbouring coil is unity.

SI unit of mutual inductance is henry(H).

1/2

1/2

(ii)

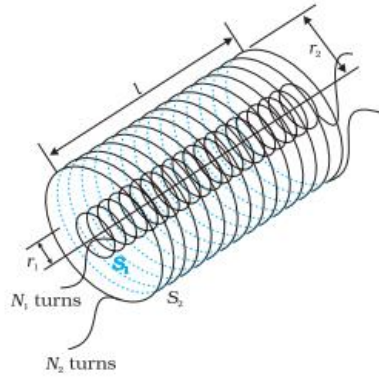

When current  $I_2$  flows in outer solenoid, the resulting flux linkage with inner solenoid.

$$N_1\phi_1 = N_1B_2A_1$$

$$N_1\phi_1 = N_1\left(\frac{\mu_0 N_2 I_2}{l}\right)\pi r_1^2$$

$$N_1\phi_1 = \frac{\mu_0 N_1 N_2 \pi r_1^2 I_2}{l} \dots\dots\dots(1)$$

$$N_1\phi_1 = M_{12}I_2 \dots\dots\dots (2)$$

From equations (1) and (2)

$$M_{12} = \frac{\mu_0 N_1 N_2 \pi r_1^2}{l}$$

OR

(b)	Defining ferromagnetic materials	1
	Explanation of ferromagnetism with diagram	2

Ferromagnetic substances are those which get strongly magnetised when placed in an external magnetic field.

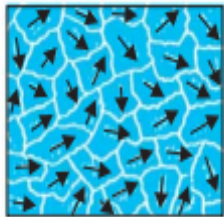

(a)

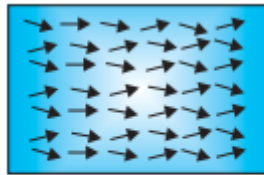

$B_0$

(b)

In absence of external magnetic field, domains are randomly oriented and it exhibits weak magnetisation.

In the presence of external magnetic field domains orient themselves in the direction of magnetic field and it exhibits strong magnetisation.

23

Finding expression for final potential of shell A	3
---	---

Charge on spherical Shell A

$$q_A = 4\pi R^2\sigma$$

Charge on spherical shell B

$$q_B = 4\pi(2R)^2\sigma = 16\pi R^2\sigma$$

After connecting by a wire, their potentials will become equal after sharing of charge.

$$\frac{1}{4\pi\epsilon_0} \frac{q'_A}{R} = \frac{1}{4\pi\epsilon_0} \frac{q'_B}{2R}$$

$$q'_B = 2q'_A$$

From conservation of charge

$$q_A + q_B = q'_A + q'_B$$

$$4\pi R^2\sigma + 16\pi R^2\sigma = 3q'_A$$

$$q'_A = \frac{20\pi R^2\sigma}{3}$$

Final potential of Shell A

$$V_A = \frac{1}{4\pi\epsilon_0} \frac{q'_A}{R}$$

$$V_A = \frac{1}{4\pi\epsilon_0} \frac{20\pi R^2\sigma}{3R}$$

$$V_A = \frac{5\sigma R}{3\epsilon_0}$$

**Alternatively**

Charge on spherical shell A

$$q_A = 4\pi R^2\sigma$$

Charge on spherical shell B

$$q_B = 4\pi(2R)^2\sigma = 16\pi R^2\sigma$$

After connecting by a wire, their potential will become equal after sharing of charges

Therefore the potential of shell A

$$\begin{aligned} V_A = V_{\text{common}} &= \frac{q_A + q_B}{C_A + C_B} \\ &= \frac{4\pi R^2\sigma + 16\pi R^2\sigma}{4\pi\epsilon_0 R + 4\pi\epsilon_0(2R)} \\ &= \frac{5\sigma R}{3\epsilon_0} \end{aligned}$$

1/2

1/2

1/2

1/2

3

1/2

1/2

1/2

1/2

1/2

1/2

24

Drawing graph showing variation of scattered particles detected (N) with scattering angle ( $\theta$ ) 1  
 Two conclusions 1  
 Obtaining expression for the distance of closest approach 1

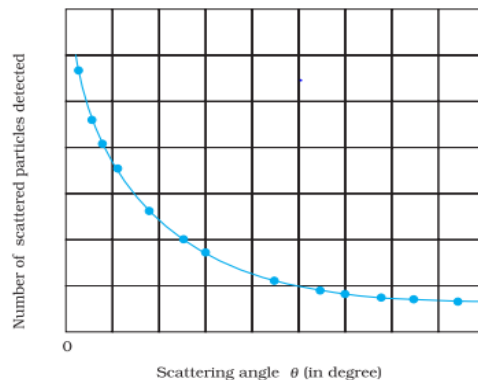

1

	<p>Two conclusions</p> <p>(i) Most of an atom is empty space.</p> <p>(ii) Almost entire mass and entire positive charge is concentrated in a very small region called nucleus.</p> <p>At distance of closest approach</p> $E_k = E_p$ $K = \frac{1}{4\pi\epsilon_0} \frac{(Ze).(2e)}{d}$ $d = \frac{1}{4\pi\epsilon_0} \frac{(2Ze^2)}{K}$	<p>1/2</p> <p>1/2</p> <p>1/2</p> <p>1/2</p>	<b>3</b>				
25	<table border="1" style="width: 100%; border-collapse: collapse;"> <tr> <td style="padding: 5px;">(i) Calculating effective resistance</td> <td style="text-align: right; padding: 5px;">2</td> </tr> <tr> <td style="padding: 5px;">(ii) Calculating power supplied by battery</td> <td style="text-align: right; padding: 5px;">1</td> </tr> </table> <p>i) <math>R_{ABC} = 10+10 = 20\Omega</math></p> <p>Equivalent resistance across AC</p> $R_{AC} = \frac{20 \times 20}{20+20} = 10\Omega$ <p>Equivalent resistance across AD</p> $R_{AD} = \frac{20 \times 20}{20+20} = 10\Omega$ <p>Equivalent resistance across AM</p> $R_{AM} = \frac{20 \times 30}{20+30} = 12\Omega$ <p>ii) Net resistance of circuit</p> $R_{net} = 12+10+8 = 30\Omega$ <p>Power supplied</p> $P = \frac{V^2}{R_{net}}$ $= \frac{(6)^2}{30}$ $= 1.2\text{ W}$ <p><b><u>Alternatively</u></b></p> <p>Net resistance of circuit</p> $R_{net} = 12+10+8 = 30\Omega$ $I = \frac{\epsilon}{R_{net}}$ $= \frac{6}{30}$ $= 0.2\text{ A}$	(i) Calculating effective resistance	2	(ii) Calculating power supplied by battery	1	<p>1/2</p> <p>1/2</p> <p>1/2</p> <p>1/2</p> <p>1/2</p> <p>1/2</p> <p>1/2</p>	<b>3</b>
(i) Calculating effective resistance	2						
(ii) Calculating power supplied by battery	1						

	<p>Power supplied</p> $P = VI$ $= 6 \times 0.2$ $= 1.2 \text{ W}$	1/2									
26	<table border="1"> <tr> <td>Finding magnitude of force</td> <td>2 1/2</td> </tr> <tr> <td>Finding direction of force</td> <td>1/2</td> </tr> </table> <p>Magnetic field at P due to infinite straight conductor carrying current</p> $\vec{B} = \frac{\mu_0 I}{2\pi r} \hat{k}$ <p>Force on charge q in this magnetic field</p> $\vec{F} = q(\vec{v} \times \vec{B})$ $\vec{F} = q \left[ (v_0 \hat{j}) \times \left( \frac{\mu_0 I}{2\pi r} \right) \hat{k} \right]$ $\vec{F} = \frac{\mu_0 q v_0 I}{2\pi r} \hat{i}$ <p>The magnitude of force <math>F = \frac{\mu_0 q v_0 I}{2\pi r}</math></p> <p>The direction of force on charge is along +ve X-axis.</p>	Finding magnitude of force	2 1/2	Finding direction of force	1/2	1/2 1/2 1/2 1/2 1/2	3				
Finding magnitude of force	2 1/2										
Finding direction of force	1/2										
27	<table border="1"> <tr> <td>Reasons for</td> <td></td> </tr> <tr> <td>i) Difference in mode of interaction of electromagnetic wave with matter</td> <td>1</td> </tr> <tr> <td>ii) Containing water in food items to be heated in microwave</td> <td>1</td> </tr> <tr> <td>iii) Wearing facemask with glasses by welders during welding</td> <td>1</td> </tr> </table> <p>(i) Since they have different wavelengths and frequencies, they differ considerably in their mode of interaction with matter.</p> <p>(ii) Frequency of microwave matches with the resonant frequency of water molecules so that energy from wave is transferred to water molecules.</p> <p>(iii) To protect their eyes from large amount of ultraviolet rays produced by welding arcs.</p>	Reasons for		i) Difference in mode of interaction of electromagnetic wave with matter	1	ii) Containing water in food items to be heated in microwave	1	iii) Wearing facemask with glasses by welders during welding	1	1 1 1	3
Reasons for											
i) Difference in mode of interaction of electromagnetic wave with matter	1										
ii) Containing water in food items to be heated in microwave	1										
iii) Wearing facemask with glasses by welders during welding	1										
28	<table border="1"> <tr> <td>(a) Difference between nuclear fission and fusion</td> <td>(1)</td> </tr> <tr> <td>(b) Calculating energy released in fission</td> <td>(2)</td> </tr> </table> <p>(a) In nuclear fission, a heavy nucleus splits into two or more lighter nuclei and energy is released. In nuclear fusion, lighter nuclei combine together to form a heavy nucleus and larger amount of energy is released.</p> <p>(b) Number of atoms in 1 g of <math>{}_{94}\text{Pu}^{239}</math></p> $= \frac{6.023 \times 10^{23}}{239}$ $= 2.5 \times 10^{21}$	(a) Difference between nuclear fission and fusion	(1)	(b) Calculating energy released in fission	(2)	1/2 1/2 1					
(a) Difference between nuclear fission and fusion	(1)										
(b) Calculating energy released in fission	(2)										



$$C = \frac{A\epsilon_0}{d - t \left(1 - \frac{1}{K}\right)}$$

1/2

ii) Total energy stored in series combination

$$\frac{1}{2} \left( \frac{C_1 C_2}{C_1 + C_2} \right) V^2 = 40 \times 10^{-3} \text{ J} \dots \dots \dots (1)$$

1/2

Energy stored in parallel combination

$$\frac{1}{2} (C_1 + C_2) V^2 = 250 \times 10^{-3} \text{ J} \dots \dots \dots (2)$$

1/2

Substituting value of V=100 V in eq (1) and (2), on solving

$$C_1 = 4 \times 10^{-5} \text{ F or } 40 \mu\text{F}$$

1/2

$$C_2 = 1 \times 10^{-5} \text{ F or } 10 \mu\text{F}$$

1/2

5

OR

b)

i) Showing electric field at a point due to a uniformly charged infinite plane sheet	3
ii) Calculating (1) electric flux through the cube	1
(2) charge enclosed by cube	1

(i)

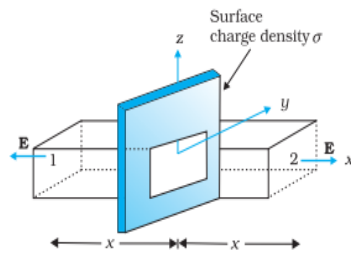

1

$$\oint \vec{E} \cdot d\vec{s} = \int_1 \vec{E} \cdot d\vec{s} + \int_2 \vec{E} \cdot d\vec{s}$$

$$= 2EA$$

1/2

From Gauss's law

$$\oint \vec{E} \cdot d\vec{s} = \frac{q}{\epsilon_0}$$

1/2

$$2EA = \frac{\sigma A}{\epsilon_0}$$

$$E = \frac{\sigma}{2\epsilon_0}$$

1/2

Vectorially  $\vec{E} = \frac{\sigma}{2\epsilon_0} \hat{n}$

1/2

Electric field is normally outward of the sheet.

(ii) (1) Electric flux through the cube

$$\phi = \phi_L + \phi_R$$

1/2

$$\phi = \int \vec{E}_L \cdot d\vec{s} + \int \vec{E}_R \cdot d\vec{s}$$

$$= -2 \times 100 \times 10^{-4} + [5 \times (10 \times 10^{-2})^2 + 2] \times 100 \times 10^{-4}$$

$$\phi = 5 \times 10^{-4} \text{ Nm}^2\text{C}^{-1}$$

1/2

(2)

$$\phi = \frac{q_{en}}{\epsilon_0}$$

$$q_{en} = \phi \cdot \epsilon_0$$

$$= 5 \times 10^{-4} \times 8.85 \times 10^{-12}$$

$$= 4.43 \times 10^{-15} \text{ C}$$

1/2

1/2

32

a) i) Drawing of ray diagram	1
Obtaining mirror equation	2
ii) Reason for using multi-component lenses	1
iii) Finding magnification produced by the objective	1

i)

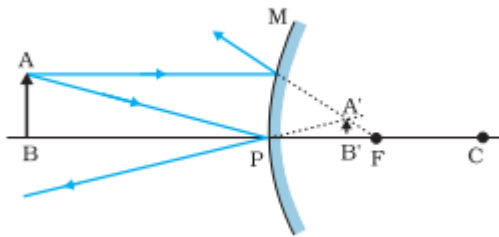

1

For paraxial rays MP can be considered to be a straight line perpendicular to CP, Therefore right angled triangles  $A'B'F$  and MPF are similar

$$\frac{B'A'}{PM} = \frac{B'F}{FP}$$

Or  $\frac{B'A'}{BA} = \frac{B'F}{FP}$  (  $\because PM = AB$  ) -----(1)

1/2

Since  $\angle APB = \angle A'PB'$ , the right angled triangles  $A'PB'$  and ABP are also similar

Therefore,  $\frac{B'A'}{BA} = \frac{B'P}{BP}$  ----- (2)

1/2

Comparing eq (1) and (2), we get

$$\frac{B'F}{FP} = \frac{B'P}{BP}$$

$$\frac{PF - PB'}{FP} = \frac{B'P}{BP}$$

Using sign convention

$PF = f$ ,  $PB' = +v$ ,  $PB = -u$

1/2

on solving  $\frac{1}{v} + \frac{1}{u} = \frac{1}{f}$

1/2

ii) To improve image quality by minimizing various optical aberrations in lenses.

1

iii) Magnification produced by compound microscope

$$m = m_o \times m_e$$

$$m_o = \frac{m}{m_e} = \frac{m}{\left| \frac{D}{fe} \right|}$$

1/2

$$m_o = \frac{200}{\frac{25}{2}} = 16$$

1/2

5

OR

(b)	i) Difference between a wavefront and a ray	1
	ii) Statement of Huygens' principle	1
	Verification of the law of reflection	1 1/2
	iii) Finding wavelength of light	1 1/2

i) Wavefront is a surface of constant phase.

1/2

**Alternatively** Locus of points, which oscillate in phase

**Ray -** The straight line path along which light travels (or energy propagates).

1/2

**Alternatively -** Ray is normal to wave front.

ii) **Huygens' Principle** Each point of the wave front is the source of secondary disturbance and the wavelets emanating from the points spread out in all directions with speed of wave. The wavelets emanating from wave front are usually referred to as secondary wavelets. A common tangent to all these spheres gives the new position of the wave front at a later time.

1

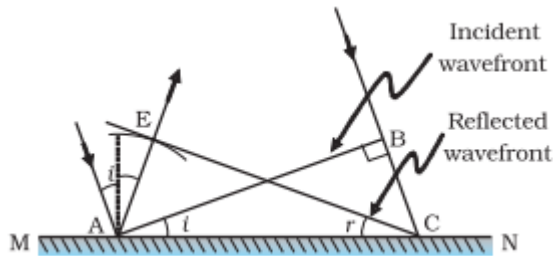

1

Triangles EAC and BAC are congruent therefore  $\angle i = \angle r$

1/2

iii) Position of 4<sup>th</sup> bright fringe

$$x_{4(\text{bright})} = 4 \frac{D\lambda}{d}$$

1/2

Position of 2<sup>nd</sup> dark fringe

$$x_{2(\text{dark})} = \frac{3}{2} \frac{D\lambda}{d}$$

1/2

$$x_{4(\text{bright})} - x_{2(\text{dark})} = 5\text{mm}$$

$$4 \frac{D\lambda}{d} - \frac{3}{2} \frac{D\lambda}{d} = 5 \times 10^{-3}$$

$$\lambda = 6 \times 10^{-6} \text{ m}$$

1/2

33

(a)	(i) Factors on which the resonant frequency of a series LCR circuit depends	1
	Plotting of graph	1
	(ii) Diagram of a transformer	1
	Working of a step-up transformer	1
	(iii) Two causes of energy loss in a real transformer	1

(i) Inductance  
Capacitance

1/2

1/2

**Alternatively**

$$v_0 = \frac{1}{2\pi\sqrt{LC}}$$

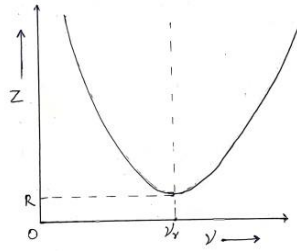

(ii)

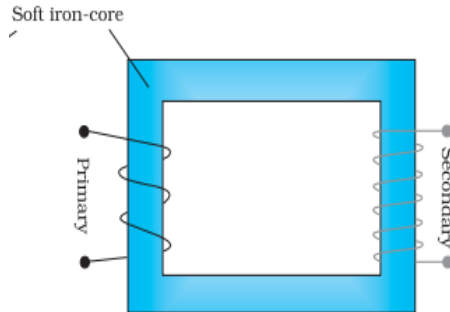

**Working** - when an alternating voltage is applied to the primary, the resulting current produces an alternating magnetic flux which links the secondary and induces an emf in it.

(iii) Causes of energy loss (any two)

- (1) Flux leakage
- (2) Resistance of the windings
- (3) Hysteresis
- (4) Eddy currents

OR

(b)

(i) Diagram of ac generator	1
Brief explanation of construction and working of ac generator	2
(ii) Obtaining expression of magnetic moment associated with revolving electron	2

(i)

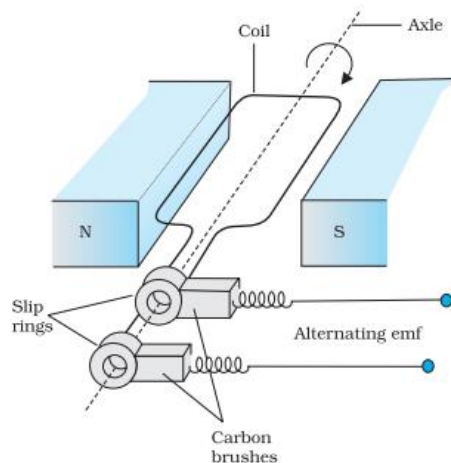

**Construction** – It consists of a coil placed in a magnetic field. The coil is mounted on a rotor shaft. The ends of the coil are connected to an external circuit by means of slip rings and brushes.

**Alternatively**

If a student draws only a labeled diagram of ac generator give 2 marks for construction and diagram.

	<p><b>Working</b> – The coil is rotated in the uniform magnetic field by some external means. The rotation of the coil causes the magnetic flux through it to change, so an emf is induced in the coil.</p> <p><b>Alternatively</b></p> <p>If a student derives <math>e = e_0 \sin \omega t</math> give one mark for working.</p> <p>(ii) The equivalent current</p> $I = \frac{q}{t} = \frac{e}{2\pi r} = \frac{ev}{2\pi r}$ <p>Magnetic moment of revolving electron</p> $m = IA$ $= \frac{ev}{2\pi r} \times \pi r^2$ $= \frac{1}{2} evr$	<p>1</p> <p><math>\frac{1}{2}</math></p> <p><math>\frac{1}{2}</math></p> <p><math>\frac{1}{2}</math></p>	
--	--	--	--