



11072CH02

2. “We’re Not Atraid to Die... if We Can All Be Together”

Gordon Cook and Alan East

*Notice these expressions in the text.
Infer their meaning from the context.*

- ◆ honing our seafaring skills
- ◆ ominous silence
- ◆ Mayday calls
- ◆ pinpricks in the vast ocean
- ◆ a tousled head

In July 1976, my wife Mary, son Jonathan, 6, daughter Suzanne, 7, and I set sail from Plymouth, England, to duplicate the round-the-world voyage made 200 years earlier by Captain James Cook. For the longest time, Mary and I — a 37-year-old businessman — had dreamt of sailing in the wake of the famous explorer, and for the past 16 years we had spent all our leisure time **honing our seafaring skills** in British waters.

Our boat *Wavewalker*, a 23 metre, 30 ton wooden-hulled beauty, had been professionally built, and we had spent months fitting it out and testing it in the roughest weather we could find.

The first leg of our planned three-year, 105,000 kilometre journey passed pleasantly as we sailed down the west coast of Africa to Cape Town. There, before heading east, we took on two crewmen — American Larry Vigil and Swiss Herb Seigler — to help us tackle one of the world’s roughest seas, the southern Indian Ocean.

On our second day out of Cape Town, we began to encounter strong gales. For the next few weeks, they blew continuously. Gales did not worry me; but the size of the waves was alarming — up to 15 metres, as high as our main mast.

December 25 found us 3,500 kilometres east of Cape Town. Despite atrocious weather, we had a wonderful holiday complete with a Christmas tree. New Year's Day saw no improvement in the weather, but we reasoned that it had to change soon. And it did change — for the worse.

At dawn on January 2, the waves were gigantic. We were sailing with only a small storm jib and were still making eight knots. As the ship rose to the top of each wave we could see endless enormous seas rolling towards us, and the screaming of the wind and spray was painful to the ears. To slow the boat down, we dropped the storm jib and lashed a heavy mooring rope in a loop across the stern. Then we double-lashed everything, went through our life-raft drill, attached lifelines, donned oilskins and life jackets — and waited.

The first indication of impending disaster came at about 6 p.m., with an **ominous silence**. The wind dropped, and the sky immediately grew dark. Then came a growing roar, and an enormous cloud towered aft of the ship. With horror, I realised that it was not a cloud, but a wave like no other I had ever seen. It appeared perfectly vertical and almost twice the height of the other waves, with a frightful breaking crest.

The roar increased to a thunder as the stern moved up the face of the wave, and for a moment I thought we might ride over it. But then a tremendous explosion shook the deck. A torrent of green and white water broke over the ship, my head smashed into the wheel and I was aware of flying overboard and sinking below the waves. I accepted my approaching death, and as I was losing consciousness, I felt quite peaceful.

Unexpectedly, my head popped out of the water. A few metres away, *Wavewalker* was near capsizing, her masts almost horizontal. Then a wave hurled her upright, my lifeline jerked taut, I grabbed the guard rails and sailed through the air into *Wavewalker's* main boom. Subsequent waves tossed me around the deck like a rag doll. My left ribs cracked; my mouth filled with blood and broken teeth. Somehow, I found the wheel, lined up the stern for the next wave and hung on.

Water, Water, Everywhere. I could feel that the ship had water below, but I dared not abandon the wheel to investigate. Suddenly, the front hatch was thrown open and Mary appeared. "We're sinking!" she screamed. "The decks are smashed; we're full of water."

"Take the wheel", I shouted as I scrambled for the hatch.

Larry and Herb were pumping like madmen. Broken timbers hung at crazy angles, the whole starboard side bulged inwards; clothes, crockery, charts, tins and toys sloshed about in deep water.

I half-swam, half-crawled into the children's cabin. "Are you all right?" I asked. "Yes," they answered from an upper bunk. "But my head hurts a bit," said Sue, pointing to a big bump above her eyes. I had no time to worry about bumped heads.

After finding a hammer, screws and canvas, I struggled back on deck. With the starboard side bashed open, we were taking water with each wave that broke over us. If I couldn't make some repairs, we would surely sink.

Somehow I managed to stretch canvas and secure waterproof hatch covers across the gaping holes. Some water continued to stream below, but most of it was now being deflected over the side.

More problems arose when our hand pumps started to block up with the debris floating around the cabins and the electric pump short-circuited. The water level rose threateningly. Back on deck I found that our two spare hand pumps had been wrenched overboard — along with the forestay sail, the jib, the dinghies and the main anchor.

Then I remembered we had another electric pump under the chartroom floor. I connected it to an out-pipe, and was thankful to find that it worked.

The night dragged on with an endless, bitterly cold routine of pumping, steering and working the radio. We were getting no replies to our **Mayday calls** — which was not surprising in this remote corner of the world.

Sue's head had swollen alarmingly; she had two enormous black eyes, and now she showed us a deep cut on her arm. When I asked why she hadn't made more of her injuries before this, she replied, "I didn't want to worry you when you were trying to save us all."

By morning on January 3, the pumps had the water level sufficiently under control for us to take two hours' rest in rotation. But we still had a tremendous leak somewhere below the waterline and, on checking, I found that nearly all the boat's main rib frames were smashed down to the keel. In fact, there was nothing holding up a whole section of the starboard hull except a few cupboard partitions.

We had survived for 15 hours since the wave hit, but *Wavewalker* wouldn't hold together long enough for us to reach Australia. I checked

our charts and calculated that there were two small islands a few hundred kilometres to the east. One of them, Ile Amsterdam, was a French scientific base. Our only hope was to reach these **pinpricks in the vast ocean**. But unless the wind and seas abated so we could hoist sail, our chances would be slim indeed. The great wave had put our auxilliary engine out of action.

On January 4, after 36 hours of continuous pumping, we reached the last few centimetres of water. Now, we had only to keep pace with the water still coming in. We could not set any sail on the main mast. Pressure on the rigging would simply pull the damaged section of the hull apart, so we hoisted the storm jib and headed for where I thought the two islands were. Mary found some corned beef and cracker biscuits, and we ate our first meal in almost two days.

But our respite was short-lived. At 4 p.m. black clouds began building up behind us; within the hour the wind was back to 40 knots and the seas were getting higher. The weather continued to deteriorate throughout the night, and by dawn on January 5, our situation was again desperate.

When I went in to comfort the children, Jon asked, "Daddy, are we going to die?" I tried to assure him that we could make it. "But, Daddy," he went on, "we aren't afraid of dying if we can all be together — you and Mummy, Sue and I."

I could find no words with which to respond, but I left the children's cabin determined to fight the sea with everything I had. To protect the weakened starboard side, I decided to heave-to — with the undamaged port hull facing the oncoming waves, using an improvised sea anchor of heavy nylon rope and two 22 litre plastic barrels of paraffin.

That evening, Mary and I sat together holding hands, as the motion of the ship brought more and more water in through the broken planks. We both felt the end was very near.

But *Wavewalker* rode out the storm and by the morning of January 6, with the wind easing, I tried to get a reading on the sextant. Back in the chartroom, I worked on wind speeds, changes of course, drift and current in an effort to calculate our position. The best I could determine was that we were somewhere in 150,000 kilometres of ocean looking for a 65 kilometre-wide island.

While I was thinking, Sue, moving painfully, joined me. The left side of her head was now very swollen and her blackened eyes narrowed to slits. She gave me a card she had made.

On the front she had drawn caricatures of Mary and me with the words: "Here are some funny people. Did they make you laugh? I laughed a lot as well." Inside was a message: "Oh, how I love you both. So this card is to say thank you and let's hope for the best." Somehow we had to make it.

I checked and rechecked my calculations. We had lost our main compass and I was using a spare which had not been corrected for magnetic variation. I made an allowance for this and another estimate of the influence of the westerly currents which flow through this part of the Indian Ocean.

About 2 p.m., I went on deck and asked Larry to steer a course of 185 degrees. If we were lucky, I told him with a conviction I did not feel, he could expect to see the island at about 5 p.m.

Then with a heavy heart, I went below, climbed on my bunk and amazingly, dozed off. When I woke it was 6 p.m., and growing dark. I knew we must have missed the island, and with the sail we had left, we couldn't hope to beat back into the westerly winds.

At that moment, **a tousled head** appeared by my bunk. "Can I have a hug?" Jonathan asked. Sue was right behind him.

"Why am I getting a hug now?" I asked.

"Because you are the best daddy in the whole world — and the best captain," my son replied.

"Not today, Jon, I'm afraid."

"Why, you must be," said Sue in a matter-of-fact voice. "You found the island."

"What!" I shouted.

"It's out there in front of us," they chorused, "as big as a battleship."

I rushed on deck and gazed with relief at the stark outline of Ile Amsterdam. It was only a bleak piece of volcanic rock, with little vegetation — the most beautiful island in the world!

We anchored offshore for the night, and the next morning all 28 inhabitants of the island cheered as they helped us ashore.

With land under my feet again, my thoughts were full of Larry and Herbie, cheerful and optimistic under the direst stress, and of Mary, who stayed at the wheel for all those crucial hours. Most of all, I thought of a seven-year-old girl, who did not want us to worry about

a head injury (which subsequently took six minor operations to remove a recurring blood clot between skin and skull), and of a six-year-old boy who was not afraid to die.

Understanding the text

1. List the steps taken by the captain
 - (i) to protect the ship when rough weather began.
 - (ii) to check the flooding of the water in the ship.
2. Describe the mental condition of the voyagers on 4 and 5 January.
3. Describe the shifts in the narration of the events as indicated in the three sections of the text. Give a subtitle to each section.

Talking about the text

Discuss the following questions with your partner.

1. What difference did you notice between the reaction of the adults and the children when faced with danger?
2. How does the story suggest that optimism helps to endure “the direst stress”?
3. What lessons do we learn from such hazardous experiences when we are face-to-face with death?
4. Why do you think people undertake such adventurous expeditions in spite of the risks involved?

Thinking about language

1. We have come across words like ‘gale’ and ‘storm’ in the account. Here are two more words for ‘storm’: typhoon, cyclone. How many words does your language have for ‘storm’?
2. Here are the terms for different kinds of vessels: yacht, boat, canoe, ship, steamer, schooner. Think of similar terms in your language.
3. ‘Catamaran’ is a kind of a boat. Do you know which Indian language this word is derived from? Check the dictionary.

4. Have you heard any boatmen's songs? What kind of emotions do these songs usually express?

Working with words

1. The following words used in the text as ship terminology are also commonly used in another sense. In what contexts would you use the other meaning?

knot	stern	boom	hatch	anchor
------	-------	------	-------	--------

2. The following three compound words end in -ship. What does each of them mean?

airship	flagship	lightship
---------	----------	-----------

3. The following are the meanings listed in the dictionary against the phrase 'take on'. In which meaning is it used in the third paragraph of the account:

take on sth: to begin to have a particular quality or appearance; to assume sth

take sb on: to employ sb; to engage sb
to accept sb as one's opponent in a game, contest or conflict

take sb/sth on: to decide to do sth; to allow sth/sb to enter e.g. a bus, plane or ship; to take sth/sb on board

Things to do

1. Given on the next page is a picture of a yacht. Label the parts of the yacht using the terms given in the box.

bow	cabin	rudder	cockpit
stern	boom	mainsail	mast

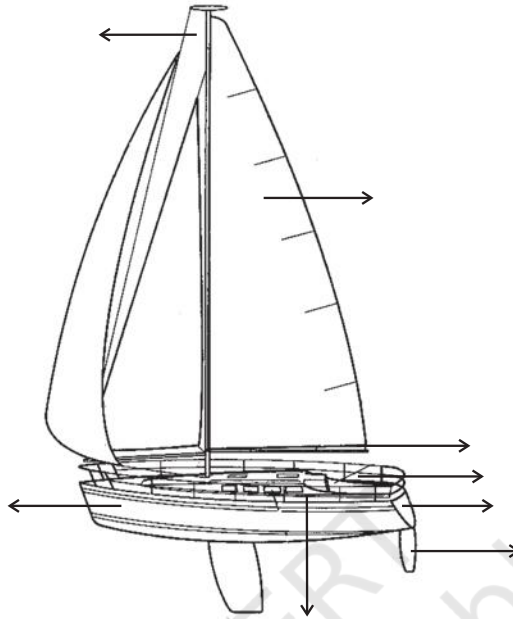

2. Here is some information downloaded from the Internet on Ile Amsterdam. You can view images of the isle if you go online.

Location	South Indian Ocean, between southernmost parts of Australia and South Africa
Latitude and longitude	37 92 S, 77 67 E
Sovereignty	France
Political status notes	Part of French Southern and Antarctic Lands
Population	35
Census notes	Meteorological station staff
Land area in square kilometres	86

3. Locate Ile Amsterdam on the world map.

Notes

This is a first person account of an adventurous ordeal that a family experiences.

Understanding the text ■

This section deals with factual and global comprehension. Practice is given in describing and noticing text organisation.

Talking about the text ■

Peer interaction about subjective responses to the text; empathy with and comment on universal experiences; and human behaviour related to risk-taking and adventure.

Thinking about language ■

- Variety of terms for a particular item in different languages
- English words derived from Indian languages
- Linking language to music (boatmen's songs)

Working with words ■

- 'Ship' terms as homonyms.
- Compound words with '-ship' with different connotations
- Phrasal verbs

Things to do ■

- Honing reference skills by finding facts from the Internet, the encyclopedia, and maps
- Exposure to various genres of fact presentation