

Marking Scheme
Strictly Confidential
(For Internal and Restricted use only)
Senior School Certificate Examination, 2023
SUBJECT PHYSICS (042) (PAPER CODE 55/4/3)

General Instructions: -

1	You are aware that evaluation is the most important process in the actual and correct assessment of the candidates. A small mistake in evaluation may lead to serious problems which may affect the future of the candidates, education system and teaching profession. To avoid mistakes, it is requested that before starting evaluation, you must read and understand the spot evaluation guidelines carefully.
2	“Evaluation policy is a confidential policy as it is related to the confidentiality of the examinations conducted, Evaluation done and several other aspects. Its’ leakage to public in any manner could lead to derailment of the examination system and affect the life and future of millions of candidates. Sharing this policy/document to anyone, publishing in any magazine and printing in News Paper/Website etc may invite action under various rules of the Board and IPC.”
3	Evaluation is to be done as per instructions provided in the Marking Scheme. It should not be done according to one’s own interpretation or any other consideration. Marking Scheme should be strictly adhered to and religiously followed. However, while evaluating, answers which are based on latest information or knowledge and/or are innovative, they may be assessed for their correctness otherwise and due marks be awarded to them. In class-X, while evaluating two competency-based questions, please try to understand given answer and even if reply is not from marking scheme but correct competency is enumerated by the candidate, due marks should be awarded.
4	The Marking scheme carries only suggested value points for the answers These are in the nature of Guidelines only and do not constitute the complete answer. The students can have their own expression and if the expression is correct, the due marks should be awarded accordingly.
5	The Head-Examiner must go through the first five answer books evaluated by each evaluator on the first day, to ensure that evaluation has been carried out as per the instructions given in the Marking Scheme. If there is any variation, the same should be zero after deliberation and discussion. The remaining answer books meant for evaluation shall be given only after ensuring that there is no significant variation in the marking of individual evaluators.
6	Evaluators will mark($\sqrt{\quad}$) wherever answer is correct. For wrong answer CROSS ‘X’ be marked. Evaluators will not put right (\checkmark)while evaluating which gives an impression that answer is correct and no marks are awarded. This is most common mistake which evaluators are committing.
7	If a question has parts, please award marks on the right-hand side for each part. Marks awarded for different parts of the question should then be totaled up and written in the left-hand margin and encircled. This may be followed strictly.
8	If a question does not have any parts, marks must be awarded in the left-hand margin and encircled. This may also be followed strictly.

9	If a student has attempted an extra question, answer of the question deserving more marks should be retained and the other answer scored out with a note “ Extra Question ”.
10	No marks to be deducted for the cumulative effect of an error. It should be penalized only once.
11	A full scale of marks 0-70 (example 0 to 80/70/60/50/40/30 marks as given in Question Paper) has to be used. Please do not hesitate to award full marks if the answer deserves it.
12	Every examiner has to necessarily do evaluation work for full working hours i.e., 8 hours every day and evaluate 20 answer books per day in main subjects and 25 answer books per day in other subjects (Details are given in Spot Guidelines). This is in view of the reduced syllabus and number of questions in question paper.
13	Ensure that you do not make the following common types of errors committed by the Examiner in the past:- <ol style="list-style-type: none"> 1. Leaving answer or part thereof unassessed in an answer book. 2. Giving more marks for an answer than assigned to it. 3. Wrong totaling of marks awarded on an answer. 4. Wrong transfer of marks from the inside pages of the answer book to the title page. 5. Wrong question wise totaling on the title page. 6. Wrong totaling of marks of the two columns on the title page. 7. Wrong grand total. 8. Marks in words and figures not tallying/not same. 9. Wrong transfer of marks from the answer book to online award list. 10. Answers marked as correct, but marks not awarded. (Ensure that the right tick mark is correctly and clearly indicated. It should merely be a line. Same is with the X for incorrect answer.) 11. Half or a part of answer marked correct and the rest as wrong, but no marks awarded.
14	While evaluating the answer books if the answer is found to be totally incorrect, it should be marked as cross (X) and awarded zero (0) Marks.
15	Any un assessed portion, non-carrying over of marks to the title page, or totaling error detected by the candidate shall damage the prestige of all the personnel engaged in the evaluation work as also of the Board. Hence, in order to uphold the prestige of all concerned, it is again reiterated that the instructions be followed meticulously and judiciously.
16	The Examiners should acquaint themselves with the guidelines given in the “ Guidelines for spot Evaluation ” before starting the actual evaluation.
17	Every Examiner shall also ensure that all the answers are evaluated, marks carried over to the title page, correctly totaled and written in figures and words.
18	The candidates are entitled to obtain photocopy of the Answer Book on request on payment of the prescribed processing fee. All Examiners/Additional Head Examiners/Head Examiners are once again reminded that they must ensure that evaluation is carried out strictly as per value points for each answer as given in the Marking Scheme.

MARKING SCHEME: PHYSICS(042)											
Code:55/4/3											
Q.No.	VALUE POINTS/EXPECTED ANSWERS	Marks	Total Marks								
SECTION – A											
Q1.	(c) $\frac{\beta}{\mu}$	1	1								
Q2.	(b) more than 2 K	1	1								
Q3.	(c) They are always attractive	1	1								
Q4.	(b) $\frac{1}{4\pi\epsilon_0 m} \left(\frac{q}{v}\right)^2$	1	1								
Q5.	(b) 1.7 eV	1	1								
Q6.	(c) Water	1	1								
Q7.	(d) S	1	1								
Q8.	(d) Infrared	1	1								
Q9.	(c) $\frac{R}{2}$ for students who have opted to answer the question in Hindi medium only. English medium students-There is misprint in the English version of the question as the word 'reflected' appear as 'refracted'. Therefore full mark to be awarded to each student who have opted to answer the question in English medium.	1	1								
Q10.	(b) 2	1	1								
Q11.	(d) along abc if I increases	1	1								
Q12.	(d) X is capacitor and $X_c = R$	1	1								
Q13.	(a) Forward biasing, 0 A	1	1								
Q14.	(b) – 3.02 eV	1	1								
Q15.	(a) 3u	1	1								
Q16.	(a) Both Assertion (A) and Reason (R) are true, and Reason (R) is the correct explanation of the Assertion (A).	1	1								
Q17.	(b) Both Assertion (A) and Reason (R) are true, but Reason (R) is not the correct explanation of the Assertion (A).	1	1								
Q18.	(d) Assertion (A) is false and Reason (R) is also false.	1	1								
SECTION - B											
Q19.	<table border="1" style="width: 100%; border-collapse: collapse;"> <tr> <td>Einstein Photoelectric equation</td> <td style="text-align: right;">½</td> </tr> <tr> <td>Identification of expression for slope and intercept</td> <td style="text-align: right;">½</td> </tr> <tr> <td>Expression for Planck's constant</td> <td style="text-align: right;">½</td> </tr> <tr> <td>Expression for work function</td> <td style="text-align: right;">½</td> </tr> </table> $\frac{1}{2}mv_m^2 = \frac{hc}{\lambda} - \phi_0$	Einstein Photoelectric equation	½	Identification of expression for slope and intercept	½	Expression for Planck's constant	½	Expression for work function	½		
Einstein Photoelectric equation	½										
Identification of expression for slope and intercept	½										
Expression for Planck's constant	½										
Expression for work function	½										

	$v_m^2 = \left(\frac{2hc}{m} \right) \frac{1}{\lambda} - \frac{2}{m} \phi_0$ <p>According to this equation a plot of v_m^2 versus $(1/\lambda)$ is a straight line.</p> <p>Slope of the graph = $\frac{2hc}{m}$</p> <p>Intercept = $\frac{2}{m} \phi_0$</p> <p>Slope and intercept can be found from the graph</p> <p>$h = \frac{m}{2c} \times \text{slope}$</p> <p>$\phi_0 = \frac{m}{2} \times \text{intercept}$</p>	<p>$\frac{1}{2}$</p> <p>$\frac{1}{2}$</p> <p>$\frac{1}{2}$</p> <p>$\frac{1}{2}$</p>	<p>2</p>		
<p>Q20.</p>	<table border="1" data-bbox="327 705 1149 761"> <tr> <td>Brief description</td> <td>2</td> </tr> </table> <p>The fusion reaction in the sun is a multi- step process in which the hydrogen is burned into helium.</p> $H_1^1 + H_1^1 \rightarrow H_2^2 + e^+ + \nu + Q_1$ $e^+ + e^- \rightarrow \gamma + \gamma + Q_2$ $H_1^2 + H_1^1 \rightarrow He_2^3 + \gamma + Q_3$ $He_2^3 + He_2^3 \rightarrow He_4^4 + H_1^1 + H_1^1 + Q_4$	Brief description	2	<p>$\frac{1}{2}$</p> <p>$\frac{1}{2}$</p> <p>$\frac{1}{2}$</p> <p>$\frac{1}{2}$</p>	<p>2</p>
Brief description	2				
<p>Q21.</p>	<table border="1" data-bbox="343 1131 1173 1187"> <tr> <td>Obtaining the expression for electric field</td> <td>2</td> </tr> </table> <div data-bbox="614 1265 821 1601" data-label="Image"> </div> <p>Flux through the Gaussian surface</p> <p>= flux through the curved cylindrical part of the surface</p> <p>= $E \times 2\pi r l$</p> <p>The surface includes charges equal to λl, Gauss's law then gives</p> $E \times 2\pi r l = \frac{\lambda l}{\epsilon_0}$ $E = \frac{\lambda}{2\pi \epsilon_0 r}$	Obtaining the expression for electric field	2	<p>$\frac{1}{2}$</p> <p>$\frac{1}{2}$</p> <p>$\frac{1}{2}$</p>	<p>2</p>
Obtaining the expression for electric field	2				

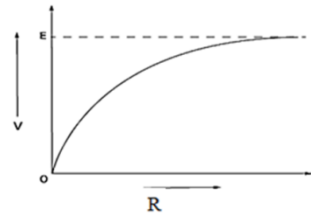
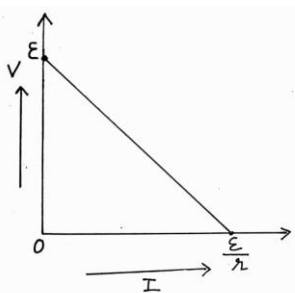
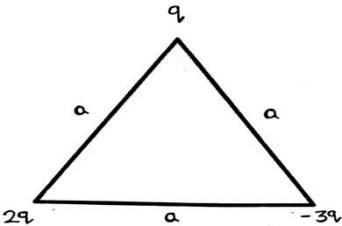
<p>Q22.</p>	<div style="border: 1px solid black; padding: 5px; margin-bottom: 10px;"> Plots of (a) Terminal voltage with R 1 (b) V with current I 1 </div> <p>(a) </p> <p>(b) </p>	<p>1</p> <p>1</p>	<p>2</p>
<p>Q23.</p>	<div style="border: 1px solid black; padding: 5px; margin-bottom: 10px;"> Specification of the direction of magnetic field for particle to move (a) straight undeviated 1 (b) in a circle 1 </div> <p>(a) For straight undeviated path, magnetic field should be set up parallel or antiparallel to velocity vector $\vec{F} = q(\vec{v} \times \vec{B})$ Alternatively: angle between \vec{v} and \vec{B}, $\theta = 0^\circ$, or $\theta = 180^\circ$ $\theta = 0^\circ$, or $\theta = 180^\circ$</p> <p>(b) If charge particle moves in circle magnetic field should be setup perpendicular to the velocity vector. $\vec{F} = q(\vec{v} \times \vec{B}) \quad \vec{v} \perp \vec{B}$</p>	<p>$\frac{1}{2}$</p> <p>$\frac{1}{2}$</p> <p>$\frac{1}{2}$</p> <p>$\frac{1}{2}$</p>	<p>2</p>
<p>Q24.</p>	<p>(a) <div style="border: 1px solid black; padding: 5px; display: inline-block;"> Obtaining expression for electric potential energy of the system 2 </div></p> <div style="text-align: center; margin-top: 20px;">  <p>OR a similar diagram with different order of charges</p> </div>		

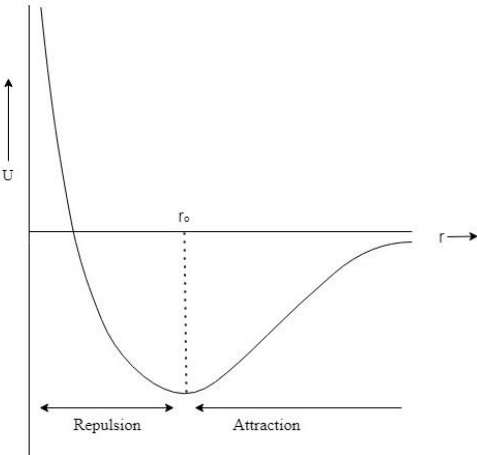
	<p>Difference: Current carried by a conductor due to flow of charges is called conduction current. Displacement current is not due to flow of charges but due to changing electric field/electric flux.</p> <p style="text-align: center;">OR</p> <p>(b) <table border="1" style="display: inline-table; vertical-align: middle;"> <tr> <td>Two characteristics</td> <td style="text-align: right;">$\frac{1}{2} + \frac{1}{2}$</td> </tr> <tr> <td>Reason for using microwave</td> <td style="text-align: right;">1</td> </tr> </table></p> <p>Any two characteristics:</p> <ol style="list-style-type: none"> 1) No medium is required for their propagation. 2) Transverse in nature. 3) Consist of Electric and Magnetic field perpendicular to each other. 4) Energy is equally shared by electrical and magnetic field. 5) Travel with speed of light in vacuum. <p>Reason: Short wavelength, do not diffract/ unidirectional property.</p>	Two characteristics	$\frac{1}{2} + \frac{1}{2}$	Reason for using microwave	1	1			
Two characteristics	$\frac{1}{2} + \frac{1}{2}$								
Reason for using microwave	1								
SECTION-C									
<p>Q26.</p>	<table border="1" style="width: 100%; border-collapse: collapse;"> <tr> <td style="padding: 5px;">Plot the variation of potential energy of two nucleons as a function of distance</td> <td style="text-align: right; padding: 5px;">1</td> </tr> <tr> <td style="padding: 5px;">Identification</td> <td style="text-align: right; padding: 5px;">$\frac{1}{2} + \frac{1}{2}$</td> </tr> <tr> <td style="padding: 5px;">Justification</td> <td style="text-align: right; padding: 5px;">$\frac{1}{2} + \frac{1}{2}$</td> </tr> </table> <div style="text-align: center; margin: 10px 0;">  </div> <p>Identification:</p> <ol style="list-style-type: none"> (i) For a separation greater than r_0, the force is attractive. (ii) for a separation less than r_0, the force is repulsive. <p>Justification: The potential energy is a minimum at a distance r_0. This means that the force is attractive for distance larger than r_0 and repulsive if they are separated by distances less than r_0.</p> <p>Alternatively: $F = -\frac{dU}{dr}$.</p> <p>For $r < r_0$, slope is negative and therefore F is positive, i.e. repulsive. For $r > r_0$, slope is positive and therefore F is negative, i.e. attractive.</p>	Plot the variation of potential energy of two nucleons as a function of distance	1	Identification	$\frac{1}{2} + \frac{1}{2}$	Justification	$\frac{1}{2} + \frac{1}{2}$	1	3
Plot the variation of potential energy of two nucleons as a function of distance	1								
Identification	$\frac{1}{2} + \frac{1}{2}$								
Justification	$\frac{1}{2} + \frac{1}{2}$								

Q27.

Finding magnitude and direction of net magnetic field at point O

3

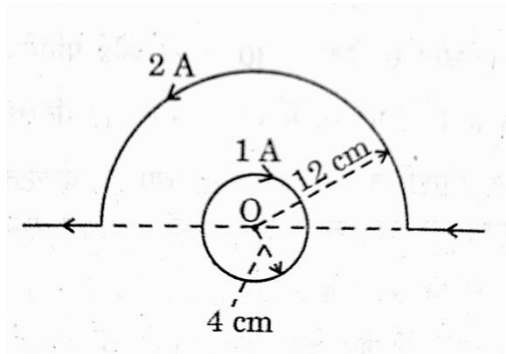

Magnetic field due to inner circle at O,

$$\begin{aligned}
 B_1 &= \frac{\mu_0 I}{2r} \\
 &= \frac{2\pi \times 10^{-7} \times 1}{4 \times 10^{-2}} \\
 &= \frac{\pi}{2} \times 10^{-5} \text{ T} \quad \text{into the page}
 \end{aligned}$$

Magnetic field due to semi-circle at O,

$$\begin{aligned}
 B_2 &= \frac{\mu_0 I}{2r} \cdot \frac{1}{2} \\
 &= \frac{2\pi \times 10^{-7} \times 2}{12 \times 10^{-2}} \\
 &= \frac{\pi}{6} \times 10^{-5} \text{ T} \quad \text{out of the page}
 \end{aligned}$$

$$\begin{aligned}
 B_{net} &= B_1 - B_2 \\
 &= \left(\frac{\pi}{2} \times 10^{-5} - \frac{\pi}{6} \times 10^{-5} \right) \text{ T} \approx 1.0 \times 10^{-5} \text{ T}
 \end{aligned}$$

Direction of the net magnetic field is into the page, since $B_1 > B_2$.

½

½

½

½

½

½

3

Q28.

(a)

- | | |
|---|---|
| (i) Explanation | 1 |
| (ii) Calculation of width | 1 |
| (iii) Plot of Intensity distribution in a diffraction pattern | 1 |

(i) For Bright fringe , $\phi = (2n + 1)\pi = 5\pi$ for $n=2$

Alternatively:

$$\Delta\phi = \frac{2\pi}{\lambda} \times \Delta x$$

1

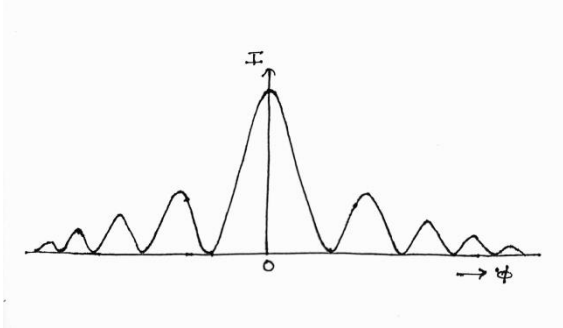
	<p>$\Delta x = \frac{5}{2} \lambda$</p> <p>(ii) We want, $a\theta = \lambda$, $\theta = \lambda/a$</p> $8 \frac{\lambda}{d} = 2 \frac{\lambda}{a} \Rightarrow a = \frac{d}{4}$ <p>(iii)</p>  <p style="text-align: center;">OR</p> <p>(b)</p> <table border="1" style="width: 100%; border-collapse: collapse;"> <tr> <td style="padding: 5px;">(i) Finding the path difference for constructive and destructive interference</td> <td style="text-align: right; padding: 5px;">2</td> </tr> <tr> <td style="padding: 5px;">(ii) Effect on interference fringes</td> <td style="text-align: right; padding: 5px;">1</td> </tr> </table> <p>(i) Net path difference between two waves reaching on the screen through two slits is given as</p> $SS_2P - SS_1P = (SS_2 - SS_1) + (S_2P - S_1P)$ $\Delta x = \frac{\lambda}{4} + (S_2P - S_1P)$ <p>For constructive interference $\Delta x = n\lambda$</p> $\therefore (S_2P - S_1P) = n\lambda - \frac{\lambda}{4} = \lambda \left(n - \frac{1}{4} \right)$ <p>For destructive interference</p> $\Delta x = (2n-1) \frac{\lambda}{2}$ $\Delta x = \frac{\lambda}{4} + (S_2P - S_1P)$ $S_2P - S_1P = (2n-1) \frac{\lambda}{2} - \frac{\lambda}{4}$ $= \frac{\lambda}{4} [4n-3]$ <p>(ii) If monochromatic source is replaced by a source of white light the centre bright fringe is white.</p>	(i) Finding the path difference for constructive and destructive interference	2	(ii) Effect on interference fringes	1	<p>1</p> <p>1</p> <p>1</p> <p>1</p> <p>1</p> <p>3</p>			
(i) Finding the path difference for constructive and destructive interference	2								
(ii) Effect on interference fringes	1								
<p>Q29.</p>	<p>(a)</p> <table border="1" style="width: 100%; border-collapse: collapse;"> <tr> <td style="padding: 5px;">(i) Calculation of current in the circuit</td> <td style="text-align: right; padding: 5px;">1</td> </tr> <tr> <td style="padding: 5px;">(ii) Calculation of voltage drop across C and R</td> <td style="text-align: right; padding: 5px;">$\frac{1}{2} + \frac{1}{2}$</td> </tr> <tr> <td style="padding: 5px;">(iii) Resolving the Paradox</td> <td style="text-align: right; padding: 5px;">1</td> </tr> </table>	(i) Calculation of current in the circuit	1	(ii) Calculation of voltage drop across C and R	$\frac{1}{2} + \frac{1}{2}$	(iii) Resolving the Paradox	1		
(i) Calculation of current in the circuit	1								
(ii) Calculation of voltage drop across C and R	$\frac{1}{2} + \frac{1}{2}$								
(iii) Resolving the Paradox	1								

	<p> $\therefore X_C = \frac{1}{\omega C}$ $\omega = 2\pi\nu = 100\pi$ $X_C = \frac{1}{100\pi \times 250/\pi \times 10^{-6}}$ $= 40\Omega$ Impedance of the circuit $Z = \sqrt{X_C^2 + R^2}$ $= \sqrt{(40)^2 + (30)^2} = 50\Omega$ (i) Current in the circuit $I_{rms} = \frac{V_{rms}}{Z} = \frac{200}{50} = 4 A$ (ii) Voltage drops across the Capacitor, $V_C = I_{rms} X_C = 4 \times 40 = 160V$ Voltage drops across the Resistor, $V_R = I_{rms} \times R = 4 \times 30 = 120V$ (iii) The algebraic sum of the two voltages V_R and V_C is 280V, which is more than the source voltage of 200V. This paradox can be removed by considering impedance triangle because V_R and V_C are out of phase by 90°, therefore $V = \sqrt{V_R^2 + V_C^2} = \sqrt{(120)^2 + (160)^2} = \sqrt{14400 + 25600} = 200V$ This is equal to the source voltage. </p> <p style="text-align: center;">OR</p> <p>(b)</p> <table border="1" style="margin-left: 20px;"> <tbody> <tr> <td>(i) Calculation of amplitude of the current at resonance</td> <td style="text-align: right;">1</td> </tr> <tr> <td>(ii) Calculation of average power at resonance</td> <td style="text-align: right;">1</td> </tr> <tr> <td>(iii) Calculation of potential drop across the capacitor</td> <td style="text-align: right;">1</td> </tr> </tbody> </table> <p>(i) At resonance, $Z=R$ $I_{rms} = \frac{200}{20} = 10A$ Amplitude of the current $I_0 = \sqrt{2} \times I_{rms}$ $I_0 = 1.414 \times 10 = 14.14 A$ (ii) Average power transferred to the circuit in one complete cycle at resonance $P = I_{rms}^2 R = (10)^2 \times 20$ $P = 2000 W$ (iii) Resonant frequency $\omega_r = \frac{1}{\sqrt{LC}} = \frac{1}{\sqrt{2 \times 50 \times 10^{-6}}} = 100 \text{ rad/s}$ $X_C = \frac{1}{\omega_r C} = \frac{1}{100 \times 50 \times 10^{-6}}$ $V_c = I_{rms} X_C = 10 \times \frac{1}{100 \times 50 \times 10^{-6}} = 2000 V$ </p>	(i) Calculation of amplitude of the current at resonance	1	(ii) Calculation of average power at resonance	1	(iii) Calculation of potential drop across the capacitor	1	<p>1</p> <p>$\frac{1}{2}$</p> <p>$\frac{1}{2}$</p> <p>$\frac{1}{2}$</p> <p>$\frac{1}{2}$</p> <p>$\frac{1}{2}$</p> <p>$\frac{1}{2}$</p> <p>$\frac{1}{2}$</p> <p>$\frac{1}{2}$</p> <p>$\frac{1}{2}$</p> <p>$\frac{1}{2}$</p>	3
(i) Calculation of amplitude of the current at resonance	1								
(ii) Calculation of average power at resonance	1								
(iii) Calculation of potential drop across the capacitor	1								

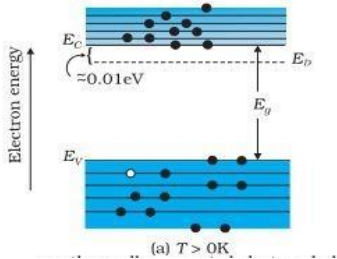
<p>Q30.</p>	<div style="border: 1px solid black; padding: 5px; margin-bottom: 10px;"> <p>(a) (i) Obtaining the expression for the current induced in the loop 1 ½</p> <p>(ii) Specifying the direction of induced current ½</p> <p>(b) Obtaining the expression for the power required to move the arm 1</p> </div> <p>(a)(i) Magnetic flux enclosed by the loop MNPQ $\phi_B = Blx$</p> <p>Since x is changing with time, the rate of change of flux ϕ_B will induce an e.m.f. given by</p> $\varepsilon = \frac{-d\phi_B}{dt} = -\frac{d}{dt}(Blx)$ $ \varepsilon = Blv$ <p>Induced current in the loop</p> $I = \frac{\varepsilon}{r} = \frac{Blv}{r}$ <p>(ii) Direction - anticlockwise or along NMQP</p> <p>(b) Power required</p> $P = Fv = IBlv$ $P = \frac{B^2 l^2 v^2}{r}$ <p style="text-align: center;">SECTION - D</p>	<p>½</p> <p>½</p> <p>½</p> <p>½</p> <p>½</p> <p>½</p>	<p>3</p>
<p>Q31.</p>	<p>(a)</p> <div style="border: 1px solid black; padding: 5px; margin-bottom: 10px;"> <p>(i) Explanation with band diagram 2</p> <p>(ii) Brief explanation of the two processes 2</p> <p>(iii) Effect on width of depletion layer 1</p> </div> <p>(i) With proper level of doping, the number of conduction electrons can be made much larger than the number of holes. Due to this conductivity of the doped crystal increases.</p> <div style="text-align: center; margin-top: 20px;">  </div>	<p>1</p> <p>1</p>	

(ii) Two processes

(a) Diffusion (b) drift

Diffusion: Due to concentration gradient majority charge carrier that is electron moves from $n \rightarrow p$ side and holes to $p \rightarrow n$ side. This movement of charges is called diffusion.

Drift: Due to the junction field, an electron on p-side of the junction moves to n- side and a hole on n- side of the junction moves to p- side. The motion of the charge carrier due to electric field is called drift.

(iii) (1) decreases
(2) increases

1

1

$\frac{1}{2}$

$\frac{1}{2}$

OR

(b)	(i) Circuit diagram	1
	Working	1
	(ii) V-I characteristics	$\frac{1}{2} + \frac{1}{2}$
	Explanation	1
	(iii) Reason	1

(i)

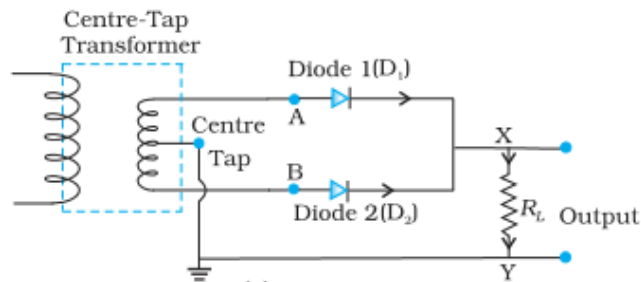

Working: Suppose the input voltage to A with respect to the centre tap at any instant is positive. At that instant voltage at B, being out of phase will be negative. So diode D_1 gets forward biased and conducts, while D_2 being reverse biased does not conduct. Similarly during second half of the cycle polarity get reversed so only D_2 will conduct.

(ii) V-I characteristics

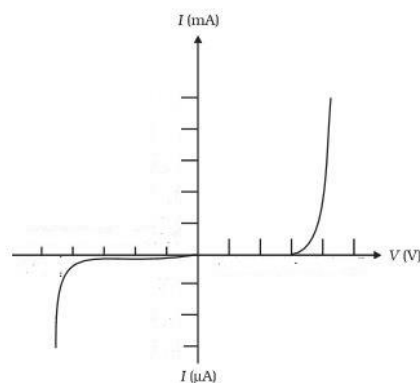

1

1

$\frac{1}{2} + \frac{1}{2}$

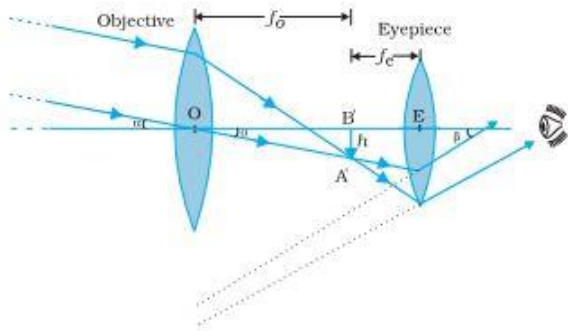
	<p>(b)</p> <table border="1" data-bbox="373 230 1114 477"> <tr> <td>(i) Definition & S.I. Unit</td> <td>1½</td> </tr> <tr> <td>(ii) Explanation of internal resistance for low voltage and high voltage battery</td> <td>1+1</td> </tr> <tr> <td>(iii) Total energy</td> <td>1½</td> </tr> </table> <p>(i) Definition : Electrical conductivity is defined as the measure of a material's ability to carry a current through it. Alternatively: It is the reciprocal of the resistivity. Alternatively: It is defined as the current density per unit electric field.</p> <p>S.I. Unit: $(\text{ohm})^{-1}\text{-m}^{-1}$ or S-m^{-1}</p> <p>(ii) Low voltage Battery- Internal resistance should be low. High voltage Battery – Internal resistance should be high.</p> <p>(iii) Applying Kirchhoff's loop rule $10 - I \times 1 - 4 - 2I - 6I - 3I = 0$ $12I = 6 \Rightarrow I = 0.5 \text{ A}$ Heat energy $H = I^2Rt$ $H = 0.25 \times 12 \times 60 = 180\text{J}$</p>	(i) Definition & S.I. Unit	1½	(ii) Explanation of internal resistance for low voltage and high voltage battery	1+1	(iii) Total energy	1½	<p>1</p> <p>½</p> <p>1</p> <p>1</p> <p>½</p> <p>½</p> <p>½</p>	<p>5</p>
(i) Definition & S.I. Unit	1½								
(ii) Explanation of internal resistance for low voltage and high voltage battery	1+1								
(iii) Total energy	1½								
<p>Q33.</p>	<p>(a)</p> <table border="1" data-bbox="373 1155 1185 1319"> <tr> <td>(i) Labelled ray diagram</td> <td>1 ½</td> </tr> <tr> <td>Derivation of expression for magnifying power</td> <td>1 ½</td> </tr> <tr> <td>(ii) Calculation of location and height of the image</td> <td>2</td> </tr> </table> <p>(i)</p>  <p>Note: Deduct ½ mark, if the direction of propagation of light is not marked.</p>	(i) Labelled ray diagram	1 ½	Derivation of expression for magnifying power	1 ½	(ii) Calculation of location and height of the image	2	<p>1 ½</p>	
(i) Labelled ray diagram	1 ½								
Derivation of expression for magnifying power	1 ½								
(ii) Calculation of location and height of the image	2								

From the diagram $\beta = \frac{h}{f_e}$

and $\alpha = \frac{h}{f_o}$

Magnifying Power = $\frac{f_o}{f_e}$

(ii)

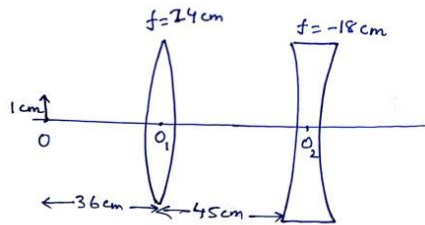

For lens L₁,

$$\frac{1}{v} - \frac{1}{u} = \frac{1}{f}$$

$$\frac{1}{v} - \frac{1}{-36} = \frac{1}{24}$$

$$\frac{1}{v} = \frac{1}{24} - \frac{1}{36}$$

$$\frac{1}{v} = \frac{3-2}{72} = \frac{1}{72}$$

$$v = 72 \text{ cm}$$

For lens L₂:

$$\frac{1}{v'} - \frac{1}{u'} = \frac{1}{f'}$$

$$\frac{1}{v'} - \frac{1}{(72-45)} = \frac{1}{-18}$$

$$\frac{1}{v'} = \frac{1}{-18} + \frac{1}{27}$$

$$\frac{1}{v'} = \frac{-3+2}{54} = \frac{-1}{54}$$

$$v' = -54 \text{ cm}$$

Final distance $v_1' = -54 - (-45)$

$$v_1' = -9 \text{ cm} \quad (\text{to the left of convex lens})$$

Magnification $\frac{h_i}{h_o} = \frac{v_1'}{u}$

$$\frac{h_i}{1} = \frac{-9}{-36} \Rightarrow h_i = +\frac{1}{4} \text{ cm}$$

1/2

1/2

1/2

1/2

1/2

1/2

1/2

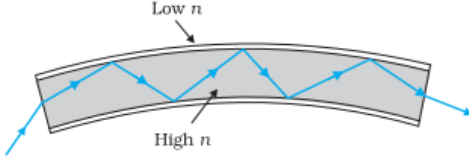
	<p style="text-align: center;">OR</p> <p>(b) (i) Working principle of an optical fibre with one use 2 (ii) Finding the angle of minimum deviation and refractive index 1+1 Effect of δ_m when the prism is immersed in water 1</p> <p>(i) Working Principle: Optical fibre uses the optical principle of total internal reflection to capture the light transmitted in an optical fibre and confine the light to the core of the fibre.</p>  <p>Uses : Transmission of audio and video signal / Examination of internal organs / Endoscopy</p> <p>(ii) $\delta_m = i + e - A$ $\delta_m = 2i - A$ $\delta_m = 60^\circ$ Refractive Index $\mu = \frac{\sin\left(\frac{A + \delta_m}{2}\right)}{\sin A/2}$ $\mu = \frac{\sin \frac{120^\circ}{2}}{\sin \frac{60^\circ}{2}}$ $\mu = \frac{\sin 60^\circ}{\sin 30^\circ} = \frac{\frac{\sqrt{3}}{2}}{\frac{1}{2}}$ $\mu = \sqrt{3}$ If the prism is immersed in water μ decreases and consequently angle of minimum deviation decreases. Since δ_m depends on μ through equation given above.</p> <p style="text-align: center;">SECTION -E</p>	<p>1</p> <p>$\frac{1}{2}$</p> <p>$\frac{1}{2}$</p> <p>$\frac{1}{2}$</p> <p>$\frac{1}{2}$</p> <p>$\frac{1}{2}$</p> <p>$\frac{1}{2}$</p> <p>1</p>	5
<p>Q34.</p>	<p>(a) Graph 1 (b) Finding the ratio Q_1/Q_2 1 (c) Calculation of potential energy 2</p> <p style="text-align: center;">OR</p> <p>Finding the work done 2</p>		

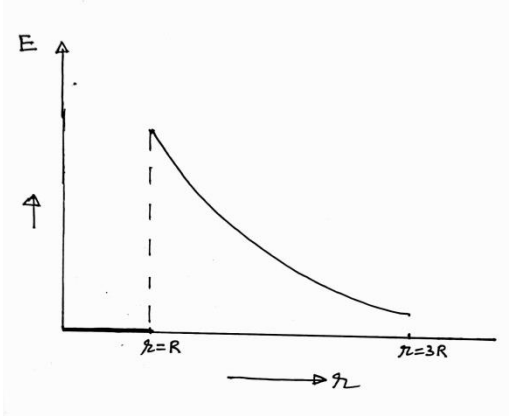
	<p>(a) </p> <p>(b) $\because V = k Q/r$ Slope of graph is proportional to Q $\frac{Q_1}{Q_2} = \frac{\tan 60^\circ}{\tan 30^\circ} = 3$</p> <p>(c) $U = - p E \cos\theta$ $\theta = 0^\circ$ $U = - (6 \times 10^{-7}) \times (10^4)$ $U = - 6 \times 10^{-3} \text{ J}$</p> <p style="text-align: center;">OR</p> <p>\because Work done $W = - p E (\cos\theta_2 - \cos\theta_1)$ where $\theta_2 = 180^\circ$, $\theta_1 = 90^\circ$ $\Rightarrow W = - p E (\cos 180^\circ - \cos 90^\circ)$ $W = + p E$</p>	<p>1</p> <p>$\frac{1}{2}$</p> <p>$\frac{1}{2}$</p> <p>$\frac{1}{2}$</p> <p>1</p> <p>$\frac{1}{2}$</p> <p>$\frac{1}{2}$</p> <p>$\frac{1}{2}$</p> <p>$\frac{1}{2}$</p>	<p>4</p>
<p>Q35.</p>	<div style="border: 1px solid black; padding: 5px; margin-bottom: 10px;"> <p>(a) Effect on Power 1</p> <p>(b) Calculation of μ 1</p> <p>(c) Calculation of focal length 2</p> <p style="text-align: center;">OR</p> <p>Calculation of object distance and image distance 1+1</p> </div> <p>(a) $P = \frac{1}{f} = (\mu - 1) \left(\frac{1}{R_1} - \frac{1}{R_2} \right)$ $\mu \propto \frac{1}{\lambda} \Rightarrow P \propto \frac{1}{\lambda}$ So P decreases as λ increases.</p> <p>(b) $\frac{1}{f} = (\mu - 1) \left(\frac{1}{R_1} - \frac{1}{R_2} \right)$ $\frac{1}{R} = (\mu - 1) \frac{2}{R} \quad (R_1 = R, R_2 = -R)$ $\Rightarrow \mu = \frac{3}{2}$</p>	<p>1</p> <p>$\frac{1}{2}$</p> <p>$\frac{1}{2}$</p>	

	<p>(c) $\frac{1}{f} = (\mu - 1) \left(\frac{1}{R_1} - \frac{1}{R_2} \right)$</p> <p>$\frac{1}{20} = \left(\frac{3}{2} - 1 \right) \left(\frac{1}{R_1} - \frac{1}{R_2} \right)$</p> <p>When the lens is immersed in water</p> <p>$\frac{1}{f_{unknown}} = \left(\frac{9}{8} - 1 \right) \left(\frac{1}{R_1} - \frac{1}{R_2} \right)$</p> <p>$\frac{1}{20} = \frac{1/2}{1/8} = \Rightarrow f = 80 \text{ cm}$</p> <p style="text-align: center;">OR</p> <p>$m = 3 = \frac{v}{u} \Rightarrow v = 3u$</p> <p>$f = \frac{100}{+5} = +20 \text{ cm}$</p> <p>$\frac{1}{v} - \frac{1}{u} = \frac{1}{f}$</p> <p>$\frac{1}{3u} - \frac{1}{u} = \frac{1}{20}$</p> <p>$\frac{1-3}{3u} = \frac{1}{20}$</p> <p>$u = -(40/3) \text{ cm}$</p> <p>$v = -40 \text{ cm}$</p>	<p>$\frac{1}{2}$</p> <p>$\frac{1}{2}$</p> <p>$\frac{1}{2}$</p> <p>$\frac{1}{2}$</p> <p>$\frac{1}{2}$</p> <p>$\frac{1}{2}$</p> <p>$\frac{1}{2}$</p> <p>$\frac{1}{2}$</p> <p>$\frac{1}{2}$</p> <p>$\frac{1}{2}$</p>	<p>4</p>
--	--	---	-----------------